

Contract Routing Form

ROUTING: Routine

printed on: 05/04/2018

Contract between: Raymond P. Cattell, Inc.
 and Dept. or Division: Engineering Division
 Name/Phone Number:

Project: Sidewalk, Curb & Gutter and Concrete Pavement Patches, Citywide Installation and Repair - 2018

Contract No.: 8075
 Enactment No.: RES-18-00335
 Dollar Amount: 462,400.00

File No.: 51213
 Enactment Date:

(Please DATE before routing)

Signatures Required	Date Received	Date Signed
City Clerk	5-8-2018	5-8-2018
Director of Civil Rights	5.8.18	5.9.18 FN3
Risk Manager	5/11/18	5/11/18 RN
Finance Director	05-11-2018	5/14/18 mcr
City Attorney	525-5-16-18	5-18-18
Mayor	05.18.18	05.18.18
Finance for scanning		me 5/18/18

Please return signed Contracts to the City Clerk's Office Room 103, City-County Building for filing.

Original + 2 Copies

05/04/2018 09:30:53 enjls - Bill McGlynn, 266,4514

Dis Rights: OK / ~~N/A~~ / Problem - Hold
 Prev Wage: AA / Agency / No
 Contract Value: 462,400.⁰⁰
 AA Plan: approved
 Amendment / Addendum # _____
 Type: POS / DMp / Sbdv / Gov't /
 Grant / PW / Goal / Loan / Agrmt



Legislation Details (With Text)

File #: 51213 **Version:** 1 **Name:** Awarding Public Works Contract No. 8075, Sidewalk, Curb & Gutter and Concrete Pavement Patches, Citywide Installation and Repair - 2018

Type: Resolution **Status:** Passed

File created: 4/12/2018 **In control:** BOARD OF PUBLIC WORKS

On agenda: 5/1/2018 **Final action:** 5/1/2018

Enactment date: 5/7/2018 **Enactment #:** RES-18-00335

Title: Awarding Public Works Contract No. 8075, Sidewalk, Curb & Gutter and Concrete Pavement Patches, Citywide Installation and Repair - 2018.

Sponsors: BOARD OF PUBLIC WORKS

Indexes:

Code sections:

Attachments: 1. Contract 8075 .pdf

Date	Ver.	Action By	Action	Result
5/1/2018	1	COMMON COUNCIL	Adopt Under Suspension of Rules 2.04, 2.05, 2.24, and 2.25	Pass
4/18/2018	1	BOARD OF PUBLIC WORKS	RECOMMEND TO COUNCIL TO ADOPT UNDER SUSPENSION OF RULES 2.04, 2.05, 2.24, & 2.25 - REPORT OF OFFICER	Pass
4/12/2018	1	Engineering Division	Refer	

The proposed resolution awards the contract for the 2018 Citywide installation and repair of sidewalk, curb, and gutter at an estimated cost of \$476,280. Funding is provided by GO Borrowing within the Engineering Bicycle and Pedestrian Sidewalk Program (MUNIS 11771).

Awarding Public Works Contract No. 8075, Sidewalk, Curb & Gutter and Concrete Pavement Patches, Citywide Installation and Repair - 2018.

BE IT RESOLVED, that the following low bids for miscellaneous improvements be accepted and that the Mayor and City Clerk be and are hereby authorized and directed to enter into a contract with the low bidders contained herein, subject to the Contractor's compliance with Section 39.02 of the Madison General Ordinances concerning compliance with the Affirmative Action provisions **and subject to the Contractor's compliance with Section 33.07 of the Madison General Ordinances regarding Best Value Contracting:**

BE IT FURTHER RESOLVED, that the funds be encumbered to cover the cost of the projects contained herein.

See attached document (Contract No. 8075) for itemization of bids.

502

PROJECT _____ CONTRACTOR _____ AMOUNT OF BID _____

CONTRACT NO. 8075
SIDEWALK, CURB & GUTTER AND CONCRETE PAVEMENT PATCHES, CITYWIDE INSTALLATION AND REPAIR
- 2018

RAYMOND P. CATTELL, INC.

\$462,400.00

Acct. No. 11771-403-200: 54425 (91382)	\$317,200.00
Contingency 3%±	<u>9,520.00</u>
Sub-Total	\$326,720.00

Acct. No. 11771-403-174: 54445 (91345)	\$2,300.00
Contingency 3%±	<u>70.00</u>
Sub-Total	\$2,370.00

Acct. No. 11674-402-200: 54410 (91384)	\$142,900.00
Contingency 3%±	<u>4,290.00</u>
Sub-Total	\$147,190.00

GRAND TOTAL	<u>\$476,280.00</u>
-------------	---------------------

Jurisdiction: Wisconsin

Demographics

Company Name: Ohio Casualty Insurance Company, The

Short Name:

SBS Company Number: 54218499

NAIC CoCode: 24074

FEIN: 31-0396250

Domicile Type: Foreign

State of Domicile: New Hampshire

Country of Domicile: United States

NAIC Group Number: 111 - LIBERTY MUT GRP

Organization Type: Stock

Date of Incorporation: 01/01/1919

Merger Flag: No

Address

Business Address

Not Available

Not Available, UN 99999

United States

Mailing Address

175 Berkeley St

Boston, MA 02116

United States

Statutory Home Office Address

62 MAPLE AVE

KEENE, NH 03431-1625

United States

Main Administrative Office Address

62 MAPLE AVE

KEENE, NH 03431-1625

United States

Phone, E-mail, Website

Phone

Type	Number
Mailing Primary Phone	(617) 357-9500
Mailing Fax Phone	(617) 574-5955
Mailing Toll Free Phone	(800) 843-6446
Statutory Home Office Primary Phone	(617) 357-9500
Statutory Home Office Toll Free Phone	(800) 843-6446
Main Admin Office Primary Phone	(617) 357-9500
Main Admin Office Toll Free Phone	(800) 843-6446

Email

No results found.

Website

No results found.

Company Type

Company Type: Property and Casualty
Status: Active
Status Reason:
Status Date: 08/02/1929
Effective Date: 10/01/2012
Legacy State ID: 110565
Issue Date: 08/02/1929
Approval Date:
File Date:
Articles of Incorporation Received: No
Article No:
COA Number:

Appointments

zahn

Licensee Name	License Number	NPN	License Type	Line of Authority	Appointment Date	Effective Date	Expiration Date
JAY ZAHN	2181567	2181567	Intermediary (Agent) Individual	Casualty	03/16/2015	03/01/2018	03/15/2019
MICHAEL ZAHN	14840439	14840439	Intermediary (Agent) Individual	Casualty	03/25/2015	03/01/2018	03/15/2019

Line Of Business

Filter

Line of Business	Citation Type	Effective Date
Aircraft	Aircraft	08/02/1929
Automobile	Automobile	08/02/1929
Credit Insurance	Credit Insurance	08/02/1929
Disability Insurance	Disability Insurance	08/02/1929
Fidelity Insurance	Fidelity Insurance	08/02/1929
Workers Compensation Insurance	Workers Compensation Insurance	08/02/1929
Liability and Incidental Medical Expense Insurance (other than automobile)	Liability and Incidental Medical Expense Insurance (other than automobile)	08/02/1929
Miscellaneous	Miscellaneous	08/02/1929
Ocean Marine Insurance	Ocean Marine Insurance	08/02/1929
Surety Insurance	Surety Insurance	08/02/1929

Contact

Filter

Contact Type	Preferred Name	Name	E-mail	Phone	Address
Registered Agent for Service of Process		*			Other CORPORATION SERVICE COMPANY 8040 EXCELSIOR DR STE 400 MADISON, WI 53717 United States

First Previous 1 Next Last

Company Merger

No results found.

Name Change History

Filter

Previous Name	New Name	Effective Date
	Ohio Casualty Insurance Company, The	

First Previous 1 Next Last

© 2018 National Association of Insurance Commissioners. All rights reserved.

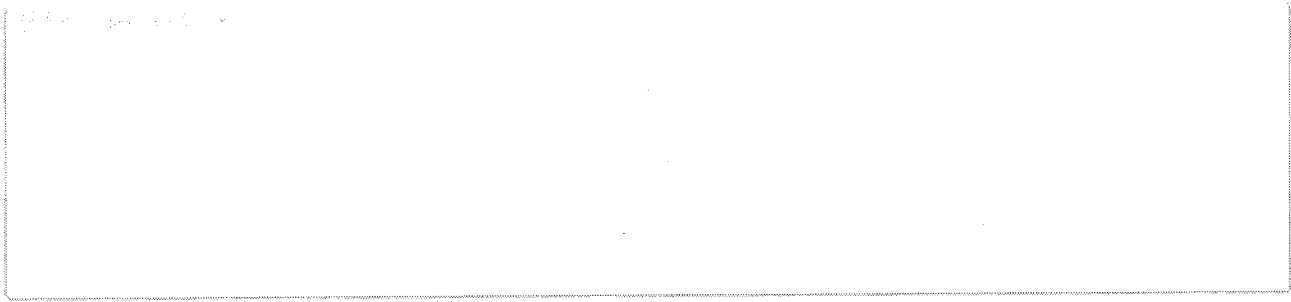

\$462,400.00
FILE

BID OF RAYMOND P. CATTELL, INC.

2018

PROPOSAL, CONTRACT, BOND AND SPECIFICATIONS

FOR

**SIDEWALK, CURB & GUTTER AND CONCRETE PAVEMENT PATCHES, CITYWIDE
INSTALLATION AND REPAIR – 2018**

CONTRACT NO. 8075

MUNIS NO. 11771

IN

MADISON, DANE COUNTY, WISCONSIN

AWARDED BY THE COMMON COUNCIL
MADISON, WISCONSIN ON **MAY 1, 2018**

CITY ENGINEERING DIVISION
1600 EMIL STREET
MADISON, WISCONSIN 53713

<https://bidexpress.com/login>

**SIDEWALK, CURB & GUTTER AND CONCRETE PAVEMENT PATCHES, CITYWIDE
INSTALLATION AND REPAIR – 2018
CONTRACT NO. 8075**

INDEX

SECTION A: ADVERTISEMENT FOR BIDS AND INSTRUCTIONS TO BIDDERS	A-1
SECTION B: PROPOSAL SECTION	B-1
SECTION C: SMALL BUSINESS ENTERPRISE	C-1
SECTION D: SPECIAL PROVISIONS	D-1
SECTION E: BIDDER'S ACKNOWLEDGEMENT	E-1
SECTION F: BEST VALUE CONTRACTING	F-1
SECTION G: BID BOND	G-1
SECTION H: AGREEMENT	H-1
SECTION I: PAYMENT AND PERFORMANCE BOND	I-1

This Proposal, and Agreement have
been prepared by:

**CITY ENGINEERING DIVISION
CITY OF MADISON
MADISON, DANE COUNTY, WISCONSIN**



Robert F. Phillips, P.E., City Engineer

RFP: wjm

SECTION A: ADVERTISEMENT FOR BIDS AND INSTRUCTIONS TO BIDDERS

REQUEST FOR BID FOR PUBLIC WORKS CONSTRUCTION CITY OF MADISON, WISCONSIN

A BEST VALUE CONTRACTING MUNICIPALITY

PROJECT NAME:	SIDEWALK, CURB & GUTTER AND CONCRETE PAVEMENT PATCHES, CITYWIDE INSTALLATION AND REPAIR – 2018
CONTRACT NO.:	8075
SBE GOAL	5%
BID BOND	5%
SBE PRE BID MEETING (1:00 P.M.)	APRIL 6, 2018
PREQUALIFICATION APPLICATION DUE (2:00 P.M.)	APRIL 5, 2018
BID SUBMISSION (2:00 P.M.)	APRIL 12, 2018
BID OPEN (2:30 P.M.)	APRIL 12, 2018
PUBLISHED IN WSJ	MARCH 29, & APRIL 5, 2018

SBE PRE BID MEETING: Representatives of the Affirmative Action Department will be present to discuss the Small Business Enterprise requirements at 1600 Emil Street, Madison Wisconsin.

PREQUALIFICATION APPLICATION: Forms are available on our website, www.cityofmadison.com/business/pw/forms.cfm. If not currently prequalified in the categories listed in Section A, an amendment to your Prequalification will need to be submitted prior to the same due date. Postmark is not applicable.

BIDS TO BE SUBMITTED by hand to 1600 EMIL ST., MADISON, WI 53713 or online at www.bidexpress.com.

THE BID OPENING is at 1600 EMIL ST., MADISON, WI 53713.

STANDARD SPECIFICATIONS

The City of Madison's Standard Specifications for Public Works Construction - 2018 Edition, as supplemented and amended from time to time, forms a part of these contract documents as if attached hereto.

These standard specifications are available on the City of Madison Public Works website, www.cityofmadison.com/Business/PW/specs.cfm.

The Contractor shall review these Specifications prior to preparation of proposals for the work to be done under this contract, with specific attention to Article 102, "BIDDING REQUIREMENTS AND CONDITIONS" and Article 103, "AWARD AND EXECUTION OF THE CONTRACT." For the convenience of the bidder, below are highlights of three subsections of the specifications.

SECTION 102.1: PRE-QUALIFICATION OF BIDDERS

In accordance with Wisconsin State Statutes 66.0901 (2) and (3), all bidders must submit to the Board of Public Works proof of responsibility on forms furnished by the City. The City requires that all bidders be qualified on a biennial basis.

Bidders must present satisfactory evidence that they have been regularly engaged in the type of work specified herein and they are fully prepared with necessary capital, materials, machinery and supervisory personnel to conduct the work to be contracted for to the satisfaction of the City. All bidders must be pre-

qualified by the Board of Public Works for the type of construction on which they are bidding prior to the opening of the bid.

In accordance with Section 39.02(9)(a)l. of the General Ordinances, all bidders shall submit in writing to the Affirmative Action Division Manager of the City of Madison, a Certificate of Compliance or an Affirmative Action Plan at the same time or prior to the submission of the proof of responsibility forms.

The bidder shall be disqualified if the bidder fails to or refuses to, prior to opening of the bid, submit a Certificate of compliance, Affirmative Action Plan or Affirmative Action Data Update, as applicable, as defined by Section 39.02 of the General Ordinances (entitled Affirmative Action) and as required by Section 102.11 of the Standard Specifications.

SECTION 102.4 PROPOSAL

No bid will be accepted that does not contain an adequate or reasonable price for each and every item named in the Schedule of Unit Prices.

A lump sum bid for the work in accordance with the plans and specifications is required. The lump sum bid must be the same as the total amounts bid for the various items and it shall be inserted in the space provided.

All papers bound with or attached to the proposal form are considered a part thereof and must not be detached or altered when the proposal is submitted. The plans, specifications and other documents designated in the proposal form will be considered a part of the proposal whether attached or not.

A proposal submitted by an individual shall be signed by the bidder or by a duly authorized agent. A proposal submitted by a partnership shall be signed by a member/partner or by a duly authorized agent thereof. A proposal submitted by a corporation shall be signed by an authorized officer or duly authorized registered agent of such corporation, and the proposal shall show the name of the State under the laws of which such corporation was chartered. The required signatures shall in all cases appear in the space provided thereof on the proposal.

Each proposal shall be placed, together with the proposal guaranty, in a sealed envelope, so marked as to indicate name of project, the contract number or option to which it applies, and the name and address of the Contractor or submitted electronically through Bid Express (www.bidexpress.com). Proposals will be accepted at the location, the time and the date designated in the advertisement. Proposals received after the time and date designated will be returned to the bidder unopened.

SECTION 102.5: BID DEPOSIT (PROPOSAL GUARANTY)

All bids, sealed or electronic, must be accompanied with a Bid Bond equal to at least 5% of the bid or a Certificate of Annual/Biennial Bid Bond or certified check, payable to the City Treasurer. Bid deposit of the successful bidders shall be returned within forty-eight (48) hours following execution of the contract and bond as required.

MINOR DISCREPENCIES

Bidder is responsible for submitting all forms necessary for the City to determine compliance with State and City bidding requirements. Notwithstanding any language to the contrary contained herein, the City may exercise its discretion to allow bidders to correct or supplement submissions after bid opening, if the minor discrepancy, bid irregularity or omission is insignificant and not one related to price, quality, quantity, time of completion or performance of the contract.

Bidders for this Contract(s) must be Pre-Qualified for at least one of the following type(s) of construction denoted by an

Building Demolition

- 101 Asbestos Removal
- 120 House Mover

- 110 Building Demolition

Street, Utility and Site Construction

- 201 Asphalt Paving
- 205 Blasting
- 210 Boring/Pipe Jacking
- 215 Concrete Paving
- 220 Con. Sidewalk/Curb & Gutter/Misc. Flat Work
- 221 Concrete Bases and Other Concrete Work
- 222 Concrete Removal
- 225 Dredging
- 230 Fencing
- 235 Fiber Optic Cable/Conduit Installation
- 240 Grading and Earthwork
- 241 Horizontal Saw Cutting of Sidewalk
- 242 Infrared Seamless Patching
- 245 Landscaping, Maintenance
- 246 Ecological Restoration
- 250 Landscaping, Site and Street
- 251 Parking Ramp Maintenance
- 252 Pavement Marking
- 255 Pavement Sealcoating and Crack Sealing
- 260 Petroleum Above/Below Ground Storage Tank Removal/Installation
- 262 Playground Installer

- 265 Retaining Walls, Precast Modular Units
- 270 Retaining Walls, Reinforced Concrete
- 275 Sanitary, Storm Sewer and Water Main Construction
- 276 Sawcutting
- 280 Sewer Lateral Drain Cleaning/Internal TV Insp.
- 285 Sewer Lining
- 290 Sewer Pipe Bursting
- 295 Soil Borings
- 300 Soil Nailing
- 305 Storm & Sanitary Sewer Laterals & Water Svc.
- 310 Street Construction
- 315 Street Lighting
- 318 Tennis Court Resurfacing
- 320 Traffic Signals
- 325 Traffic Signing & Marking
- 332 Tree pruning/removal
- 333 Tree, pesticide treatment of
- 335 Trucking
- 340 Utility Transmission Lines including Natural Gas, Electrical & Communications
- 399 Other _____

Bridge Construction

- 501 Bridge Construction and/or Repair

Building Construction

- 401 Floor Covering (including carpet, ceramic tile installation, rubber, VCT)
- 402 Building Automation Systems
- 403 Concrete
- 404 Doors and Windows
- 405 Electrical - Power, Lighting & Communications
- 410 Elevator - Lifts
- 412 Fire Suppression
- 413 Furnishings - Furniture and Window Treatments
- 415 General Building Construction, Equal or Less than \$250,000
- 420 General Building Construction, \$250,000 to \$1,500,000
- 425 General Building Construction, Over \$1,500,000
- 428 Glass and/or Glazing
- 429 Hazardous Material Removal
- 430 Heating, Ventilating and Air Conditioning (HVAC)
- 433 Insulation - Thermal
- 435 Masonry/Tuck pointing

- 437 Metals
- 440 Painting and Wallcovering
- 445 Plumbing
- 450 Pump Repair
- 455 Pump Systems
- 460 Roofing and Moisture Protection
- 464 Tower Crane Operator
- 461 Solar Photovoltaic/Hot Water Systems
- 465 Soil/Groundwater Remediation
- 466 Warning Sirens
- 470 Water Supply Elevated Tanks
- 475 Water Supply Wells
- 480 Wood, Plastics & Composites - Structural & Architectural
- 499 Other _____

State of Wisconsin Certifications

- 1 Class 5 Blaster - Blasting Operations and Activities 2500 feet and closer to inhabited buildings for quarries, open pits and road cuts.
- 2 Class 6 Blaster - Blasting Operations and Activities 2500 feet and closer to inhabited buildings for trenches, site excavations, basements, underwater demolition, underground excavations, or structures 15 feet or less in height.
- 3 Class 7 Blaster - Blasting Operations and Activities for structures greater than 15' in height, bridges, towers, and any of the objects or purposes listed as "Class 5 Blaster or Class 6 Blaster".
- 4 Petroleum Above/Below Ground Storage Tank Removal and Installation (Attach copies of State Certifications.)
- 5 Hazardous Material Removal (Contractor to be certified for asbestos and lead abatement per the Wisconsin Department of Health Services, Asbestos and Lead Section (A&LS).) See the following link for application: www.dhs.wisconsin.gov/Asbestos/Cert. State of Wisconsin Performance of Asbestos Abatement Certificate must be attached.
- 6 Certification number as a Certified Arborist or Certified Tree Worker as administered by the International Society of Arboriculture
- 7 Pesticide application (Certification for Commercial Applicator For Hire with the certification in the category of turf and landscape (3.0) and possess a current license issued by the DATCP)
- 8 State of Wisconsin Master Plumbers License.

SECTION B: PROPOSAL

Please refer to the
Bid Express Website
at <https://bidexpress.com>
look up contract number
and go to
Section B: Proposal Page

You can access all City of Madison bid solicitations for FREE at www.bidexpress.com

Click on the "Register for Free" button and follow the instructions to register your company and yourself. You will be asked for a payment subscription preference, since you may wish to bid online someday. Simply choose the method to pay on a 'per bid' basis. This requires no payment until / unless you actually bid online. You can also choose the monthly subscription plan at this time. You will, however, be asked to provide payment information. Remember, you can change your preference at anytime. You will then be able to complete your free registration and have full access to the site. Your free access does not require completion of the 'Digital ID' process, so you will have instant access for viewing and downloading. To be prepared in case you ever do wish to bid online, you may wish to establish your digital ID also, since you cannot bid without a Digital ID.

If you have any problems with the free registration process, you can call the bidexpress help team, toll free at 1-888-352-2439 (option 1, option1).

SECTION C: SMALL BUSINESS ENTERPRISE

Instructions to Bidders City of Madison SBE Program Information

2 Small Business Enterprise (SBE) Program Information

2.1 Policy and Goal

The City of Madison reaffirms its policy of nondiscrimination in the conduct of City business by maintaining a procurement process which remains open to all who have the potential and ability to sell goods and services to the City. It is the policy of the City of Madison to allow Small Business Enterprises (SBE) maximum feasible opportunity to participate in City of Madison contracting. The bidder acknowledges that its bid has been submitted in accordance with the SBE program and is for the public's protection and welfare.

Please refer to the "ADVERTISEMENT FOR BIDS" for the goal for the utilization of SBEs on this project. SBEs may participate as subcontractors, vendors and/or suppliers, which provide a commercially useful function. The dollar value for SBE suppliers or 'materials only' vendors shall be discounted to 60% for purposes of meeting SBE goals.

A bidder which achieves or exceeds the SBE goal will be in compliance with the SBE requirements of this project. In the event that the bidder is unable to achieve the SBE goal, the bidder must demonstrate that a good faith effort to do so was made. Failure to either achieve the goal or demonstrate a good faith effort to do so will be grounds for the bidder being deemed a non-responsible contractor ineligible for award of this contract.

A bidder may count towards its attainment of the SBE goal only those expenditures to SBEs that perform a commercially useful function. For purposes of evaluating a bidder's responsiveness to the attainment of the SBE goal, the contract participation by an SBE is based on the percentage of the total base bid proposed by the Contractor. The total base bid price is inclusive of all addenda.

Work performed by an SBE firm in a particular transaction can be counted toward the goal only if it involves a commercially useful function. That is, in light of industry practices and other relevant considerations, does the SBE firm have a necessary and useful role in the transaction, of a kind for which there is a market outside the context of the SBE Program, or is the firm's role a superfluous step added in an attempt to obtain credit towards goals? If, in the judgment of the Affirmative Action Division, the SBE firm will not perform a commercially useful function in the transaction, no credit towards goals will be awarded.

The question of whether a firm is performing a commercially useful function is completely separate from the question of whether the firm is an eligible SBE. A firm is eligible if it meets the definitional criteria and ownership and control requirements, as set forth in the City of Madison's SBE Program.

If the City of Madison determines that the SBE firm is performing a commercially useful function, then the City of Madison must then decide what that function is. If the commercially useful function is that of an SBE vendor / supplier that regularly transacts business with the respective product, then the City of Madison will count 60% of the value of the product supplied toward SBE goals.

To be counted, the SBE vendor / supplier must be engaged in selling the product in question to the public. This is important in distinguishing an SBE vendor / supplier, which has a regular trade with a variety of customers, from a firm which performs supplier-like functions on an ad hoc basis or for only one or two contractors with whom it has a special relationship.

A supplier of bulk goods may qualify as an eligible SBE vendor / supplier if it either maintains an inventory or owns or operates distribution equipment. With respect to the distribution equipment; e.g., a fleet of trucks, the term "operates" is intended to cover a situation in which the supplier leases the equipment on a regular basis for its entire business. It is not intended to cover a situation in which the firm simply provides drivers for trucks owned or leased by another party; e.g., a prime contractor, or leases such a party's trucks on an ad hoc basis for a specific job.

If the commercially useful function being performed is not that of a qualified SBE vendor / supplier, but rather that of delivery of products, obtaining bonding or insurance, procurement of personnel, acting as a broker or manufacturer's representative in the procurement of supplies, facilities, or materials, etc., only the fees or commissions will apply towards the goal.

For example, a business that simply transfers title of a product from manufacturer to ultimate purchaser; e. g., a sales representative who re-invoices a steel product from the steel company to the Contractor, or a firm that puts a product into a container for delivery would not be considered a qualified SBE vendor / supplier. The Contractor would not receive credit based on a percentage of the cost of the product for working with such firms.

Concerning the use of services that help the Contractor obtain needed supplies, personnel, materials or equipment to perform a contract: only the fee received by the service provider will be counted toward the goal. For example, use of a SBE sales representative or distributor for a steel company, if performing a commercially useful function at all, would entitle the Contractor receiving the steel to count only the fee paid to the representative or distributor toward the goal. This provision would also govern fees for professional and other services obtained expressly and solely to perform work relating to a specific contract.

Concerning transportation or delivery services: if an SBE trucking company picks up a product from a manufacturer or a qualified vendor / supplier and delivers the product to the Contractor, the commercially useful function it is performing is not that of a supplier, but simply that of a transporter of goods. Unless the trucking company is itself the manufacturer or a qualified vendor / supplier in the product, credit cannot be given based on a percentage of the cost of the product. Rather, credit would be allowed for the cost of the transportation service.

The City is aware that the rule's language does not explicitly mention every kind of business that may contribute work on this project. In administering these programs, the City would, on a case-by-case basis, determine the appropriate counting formula to apply in a particular situation.

2.2 Contract Compliance

Questions concerning the SBE Program shall be directed to the Contract Compliance Officer of the City of Madison Department of Civil Rights, Affirmative Action Division, 210 Martin Luther King, Jr. Blvd., Room 523, Madison, WI 53703; telephone (608) 266-4910.

2.3 Certification of SBE by City of Madison

The Affirmative Action Division maintains a directory of SBEs which are currently certified as such by the City of Madison. Contact the Contract Compliance Officer as indicated in Section 2.2 to receive a copy of the SBE Directory or you may access the SBE Directory online at www.cityofmadison.com/dcr/aaTBDir.cfm.

All contractors, subcontractors, vendors and suppliers seeking SBE status must complete and submit the **Targeted Business Certification Application** to the City of Madison Affirmative Action Division by the time and date established for receipt of bids. A copy of the Targeted Business Certification Application is available by contacting the Contract Compliance Officer at the address and telephone indicated in Section 2.2 or you may access the Targeted Business Certification Application online at www.cityofmadison.com/dcr/aaTBDir.cfm. Submittal of the Targeted Business Certification Application by the time specified does not guarantee that the applicant will be certified as a SBE eligible to be utilized towards meeting the SBE goal for this project.

2.4 Small Business Enterprise Compliance Report

2.4.1 Good Faith Efforts

Bidders shall take all necessary affirmative steps to assure that SBEs are utilized when possible and that the established SBE goal for this project is achieved. A contractor who self performs a portion of the work, and is pre-qualified to perform that category of work, may subcontract that portion of the work, but shall not be required to do so. When a bidder is unable to achieve the established SBE goal, the bidder must demonstrate that a good faith effort to do so was made. Such a good faith effort should include the following:

- 2.4.1.1 Attendance at the pre-bid meeting.
- 2.4.1.2 Using the City of Madison's directory of certified SBEs to identify SBEs from which to solicit bids.
- 2.4.1.3 Assuring that SBEs are solicited whenever they are potential sources.
- 2.4.1.4 Referring prospective SBEs to the City of Madison Affirmative Action Division for certification.
- 2.4.1.5 Dividing total project requirements into smaller tasks and/or quantities, where economically feasible, to permit maximum feasible SBE participation.
- 2.4.1.6 Establishing delivery schedules, where requirements permit, which will encourage participation by SBEs.
- 2.4.1.7 Providing SBEs with specific information regarding the work to be performed.
- 2.4.1.8 Contacting SBEs in advance of the deadline to allow such businesses sufficient time to prepare a bid.
- 2.4.1.9 Utilizing the bid of a qualified and competent SBE when the bid of such a business is deemed reasonable (i.e. 5% above the lowest bidder), although not necessarily low.
- 2.4.1.10 Contacting SBEs which submit a bid, to inquire about the details of the bid and confirm that the scope of the work was interpreted as intended.
- 2.4.1.11 Completion of Cover Page (page C-6), Summary Sheet (page C-7) and SBE Contact Reports (pages C-8 and C9) if applicable.

2.4.2 Reporting SBE Utilization and Good Faith Efforts

The Small Business Enterprise Compliance Report is to be submitted by the bidder with the bid: This report is due by the specified bid closing time and date. Bids submitted without a completed SBE Compliance Report as outlined below may be deemed non-responsible and the bidder ineligible for award of this contract. Notwithstanding any language to the contrary contained herein, the City may exercise its discretion to allow bidders to correct or supplement submissions after bid opening, if the minor discrepancy, bid irregularity or omission is insignificant and not one related to price, quality, quantity, time of completion, performance of the contract, or percentage of SBE utilization.

2.4.2.1 If the Bidder meets or exceeds the goal established for SBE utilization, the Small Business Enterprise Compliance Report shall consist of the following:

2.4.2.1.1 **Cover Page**, Page C-6; and

2.4.2.1.2 **Summary Sheet**, C-7.

2.4.2.2 If the bidder does not meet the goal established for SBE utilization, the Small Business Enterprise Compliance Report shall consist of the following:

2.4.2.2.1 **Cover Page**, Page C-6;

2.4.2.2.2 **Summary Sheet**, C-7; and

2.4.2.2.3 **SBE Contact Report**, C-8 and C-9. (A separate Contact Report must be completed for each applicable SBE which is not utilized.)

2.5 Appeal Procedure

A bidder which does not achieve the established goal and is found non-responsible for failure to demonstrate a good faith effort to achieve such goal and subsequently denied eligibility for award of contract may appeal that decision to the Small Business Enterprises Appeals Committee. All appeals shall be made in writing, and shall be delivered to and received by the City Engineer no later than 4:30 PM on the third business day following the bidder's receipt of the written notification of ineligibility by the Affirmative Action Division Manager. Postmark not acceptable. The notice of appeal shall state the basis for the appeal of the decision of the Affirmative Action Division Manager. The Appeal shall take place in accordance with Madison General Ordinance 33.54.

2.6 SBE Requirements After Award of the Contract

The successful bidder shall identify SBE subcontractors, suppliers and vendors on the subcontractor list in accordance with the specifications. The Contractor shall submit a detailed explanation of any variances between the listing of SBE subcontractors, vendors and/or suppliers on the subcontractor list and the Contractor's SBE Compliance Report for SBE participation.

No change in SBE subcontractors, vendors and/or suppliers from those SBEs indicated in the SBE Compliance Report will be allowed without prior approval from the Engineer and the Affirmative Action Division. The contractor shall submit in writing to the City of Madison Affirmative Action Division a request to change any SBE citing specific reasons which necessitate such a change. The Affirmative Action Division will use a general test of reasonableness in approving or rejecting the contractor's request for change. If the request is approved, the Contractor will make every effort to utilize another SBE if available.

The City will monitor the project to ensure that the actual percentage commitment to SBE firms is carried out.

2.7 SBE Definition and Eligibility Guidelines

A Small Business Enterprise is a business concern awarded certification by the City of Madison. For the purposes of this program a Small Business Enterprise is defined as:

- A. An independent business operated under a single management. The business may not be a subsidiary of any other business and the stock or ownership may not be held by any individual or any business operating in the same or a similar field. In determining whether an entity qualifies as a SBE, the City shall consider all factors relevant to being an independent business including, but not limited to, the date the business was established, adequacy of its resources for the work in which it proposes to involve itself, the degree to which financial, equipment leasing and other relationships exist with other ineligible firms in the same or similar lines of work. SBE owner(s) shall enjoy the customary incidents of ownership and shall share in the risks and profits commensurate with their enjoyment interests, as demonstrated by an examination of the substance rather than form or arrangements that may be reflected in its ownership documents.
- B. A business that has averaged no more than \$4.0 million in annual gross receipts over the prior three year period and the principal owner(s) do not have a personal net worth in excess of \$1.32 million.

Firm and/or individuals that submit fraudulent documents/testimony may be barred from doing business with the City and/or forfeit existing contracts.

SBE certification is valid for one (1) year unless revoked.

SECTION D: SPECIAL PROVISIONS

SIDEWALK, CURB & GUTTER AND CONCRETE PAVEMENT PATCHES, CITYWIDE INSTALLATION AND REPAIR – 2018 CONTRACT NO. 8075

It is the intent of these Special Provisions to set forth the final contractual intent as to the matter involved and shall prevail over the Standard Specifications and plans whenever in conflict therewith. In order that comparisons between the Special Provisions can be readily made, the numbering system for the Special Provisions is equivalent to that of the Specifications.

Whenever in these Specifications the term "Standard Specifications" appears, it shall be taken to refer to the City of Madison Standard Specifications for Public Works Construction and Supplements thereto.

SECTION 102.12: BEST VALUE CONTRACTING

This Contract shall be considered a Best Value Contract if the Contractor's bid is equal to or greater than \$61,000 for a single trade contract; or equal to or greater than \$297,500 for a multi-trade contract pursuant to MGO 33.07(7).

SECTION 104 SCOPE OF WORK

The Contractor shall perform work at various locations throughout the City, as ordered by the Common Council, or as directed by the Engineer. This work includes various locations of replacing defective sidewalk, curb and gutter, concrete pavement repairs, storm sewer, sidewalk ramps including detectable warning fields (supplied by the City of Madison) and associated work. There are also locations where new sidewalk and associated work shall be installed. A list of approved locations and detail drawings are included with these Special Provisions. The list, however, is not a final list. Additional locations may be added.

An interim completion date of July 27, 2018 is required for all work included with these Special Provisions. Any work added to the contract by September 14, 2018 shall be completed by November 16, 2018. Work added after September 14, 2018 shall be completed in a timeframe mutually agreed upon by the Contractor and City. Liquidated damages in accordance with Section 109.9 of the Standard Specifications shall apply to all completion dates noted above.

No work shall take place on the UW Campus on August 14 and 15, 2018.

The Contractor shall review sites listed in these Special Provisions prior to bidding to become familiar with the existing conditions. It will be the responsibility of the Contractor to work with utilities located in the right of way to resolve conflicts during the construction process.

SECTION 104.3 CHANGES IN THE WORK

The quantities of the items listed in this Contract are estimates only, based upon past year's request work and known request work on file at the time this Contract was bid. The quantities of the items are subject to change.

The City reserves the right to decrease or increase any of the quantities of the items bid upon without any change in the unit price bid.

If the quantity of any item is reduced, such decrease **SHALL NOT** constitute a claim for damages by the Contractor for loss of anticipated profits, **NOR** shall the Contractor be compensated for any overhead, equipment, material, and labor charges, or any other costs incurred in the expectation of any quantity of work originally estimated in the Contract.

SECTION 104.10 CLEANING UP

Remaining concrete dust shall be cleaned and removed from sidewalk surface as well as surrounding railings, sidewalk, pavement, driveways, landscaping, or other objects in the vicinity of work upon completion of concrete sawcutting.

Excess concrete from finishing operations and from spillage on adjacent sidewalk and/or street shall be removed immediately.

This work shall be incidental to operations connected with this contract.

SECTION 105.12 COOPERATION BY CONTRACTOR

The Contractor shall coordinate the work under this contract with various City of Madison Public Works construction projects.

SECTION 107.1 PUBLIC CONVENIENCE AND SAFETY

The Contractor shall strictly adhere to Section 182.0175, Wisconsin Statutes, regarding notification and location of utilities, including but not limited to three working days advance notice. The Contractor shall notify the Diggers Hotline at 1-800-242-8511 before moving onto and starting work on each of the various streets.

The contractor shall not work on sidewalks on streets within two blocks of schools while in session.

If sidewalk exists on both sides of any given block, the Contractor shall complete all repairs and reopen the sidewalk on one side of the block before beginning repairs on the opposite side of the block.

The contractor shall coordinate work with other construction projects so that sidewalk is open on one side of the street at all times.

The Contractor shall properly barricade and light all work areas in accordance with the City of Madison Standards for Sidewalk and Bike Closures and the State of Wisconsin Standard Detail Drawing S.D.D. 15D 30-1.

Access to all residential driveways within the project limits shall be maintained whenever possible. During times when work will impede or prevent vehicular access to driveways, the Contractor shall notify all residents a minimum of 48 hours in advance, if vehicular access cannot be provided to their property. All driveway access shall be restored within ten (10) days of removal, including concrete cure time and asphalt paving.

Access to commercial driveways and multi-family units shall be maintained at all times unless arrangements are made with the property owner and approved by the Engineer. No additional compensation shall be given for maintaining access.

SECTION 107.2 PROTECTION AND RESTORATION OF PROPERTY AND PROPERTY MONUMENTS

Care shall be taken not to disturb property irons, sodded areas, and retaining walls on private property. The Contractor shall use care around all existing trees, plantings, fences, walls, steps and driveways that are to remain. Damage to these items during construction shall be repaired or replaced at the Contractor's expense.

Sidewalk forms, form pins and all other items incidental to the work shall not be left or stored on the sidewalk or on private property.

SECTION 107.6 DUSTPROOFING

Whenever sawcutting of concrete is required, the sawcutting shall be done by a means that will eliminate any dust.

The Contractor shall take all necessary steps to control dust arising from operations connected with this contract. When ordered by the Engineer, the Contractor shall dustproof the construction area by using power sweepers and water. Dustproofing shall be incidental with the operations connected with this contract.

SECTION 107.7 MAINTENANCE OF TRAFFIC

Work requiring lane closures on collector or arterial streets shall require a Traffic Control Plan approved by the City Traffic Engineer, at 215 Martin Luther King Jr. Blvd, Suite 100, Madison, WI 53703. The Contractor shall contact Mark Winter at 266-6543. The Contractor shall not start work within the arterial street lane closure area until the Traffic Engineering Department has approved the Traffic Control Plan and traffic control devices have been installed, in accordance with the approved plan. Failure of the Contractor to obtain approval of a Traffic Control Plan, as specified above, may prevent the Contractor from starting work and shall be considered a delay of the project, caused by the Contractor. Peak hour traffic restrictions may apply as directed by the Traffic Engineer.

On-street parking may be removed by the Contractor to facilitate sidewalk construction and maintain traffic flow. The Contractor shall notify the Traffic Engineering Department forty-eight (48) hours in advance of proposed parking removal. The Contractor shall obtain from the City and place "No Parking" portables, "No Parking" cardboard signs or meter bags whichever is applicable for the particular street. "No Parking" must be posted in advance of construction.

On streets without time restricted parking, the Contractor shall post said streets at least forty eight (48) hours prior to beginning work with "No Parking" signs legibly marked with the date and time of restricted parking. The Contractor shall notify the Police Department Traffic Bureau at 266-4622 during regular hours or the Police Dispatcher after regular hours stating the construction company name, the contract number, the street or streets posted, the time and date posted, and shall request the police department personnel check the posting.

On streets with time restricted parking, the Contractor shall post said street at least twelve hours prior to beginning work with "No Parking" signs legibly marked with the date and time of restricted parking. The Contractor shall notify the Police Department Traffic Bureau at 266-4622 during regular hours or the Police Dispatcher after regular hours stating the construction company name, the contract number, the street or streets posted, the time and date posted, and shall request the police department personnel check the posting.

On all streets where residential permit parking is allowed, the Contractor shall post said street at least forty-eight (48) hours prior to beginning work with "No Parking" signs legibly marked with the date and time of restricted parking. Residential permit parking zones are indicated with a zone number on a lower corner of the permanent time restriction sign. The Contractor shall notify the Police Department Traffic Bureau at 266-4622 during regular hours or the Police Dispatcher after regular hours stating the construction company name, the contract number, the street or streets posted, the time and date posted, and shall request the police department personnel check the posting.

"No Parking" signs shall be posted a minimum of three (3) feet above curb elevations. If no work is begun on the posted street within two (2) days of the posted start date, the Contractor shall remove the "No Parking" signs and repost the street when ready to begin work on that street.

The Contractor shall maintain two-way traffic during the performance of all work covered by the contract.

Traffic control shall consist of furnishing and maintaining all provisions for traffic control in accordance with the Federal Highway Administrations "Manual on Uniform Traffic Control Devices"(MUTCD), the City

of Madison Standards for Sidewalk and Bike Closures and the State of Wisconsin Standard Detail Drawing S.D.D. 15D 30-1.

No construction equipment or materials shall be stored in the peak hour restriction roadway or street right-of-way that is open to traffic during non-working hours.

Work shall be arranged so that there is a minimum of interference with ingress and egress to private property. The Contractor shall furnish and install 3/4" crushed stone or crushed concrete on walkways and driveways as directed by the Engineer. All costs for this work shall be incidental to the various items of construction.

This contract does not include a separate contract item for Traffic Control. All the work herein before prescribed, required and performed will not be separately measured for payment, but will be considered incidental to other items in the contract.

No work shall occur during peak hour traffic times on collector and arterial streets and as directed by the Engineer. Peak hour traffic times are 7:00 a.m. to 8:30 a.m. and 4:00 p.m. to 5:30 p.m.

SECTION 107.8 NOTIFICATION WHEN CLOSING STREET

The Contractor shall not remove traffic signs. For removal and replacement of traffic and parking signs, contact the City of Madison Traffic Engineering Operations, 1120 Sayle Street, 266-4767, 8:00 a.m. to 4:00 p.m., a minimum of one (1) working day in advance of when any existing signs need to be removed. This service is provided free of charge. If the Contractor removes the signs, the Contractor will be billed for the reinstallation of, and any damage to, signing equipment.

SECTION 107.9 BARRICADES, WARNING SIGNS AND FLAGMEN

Should the Contractor require occupying a lane of traffic on an arterial street during non-peak hours, an electric arrow board and appropriate signing will be required. The cost of the arrow board and signing shall be at the Contractor's expense.

The Contractor shall barricade and light all work areas in accordance with the Federal Highway Administrations "Manual on Uniform Traffic Control Devices" (MUTCD).

Electric lighting (flashers) shall be used for lighting of work areas. Type II barricades shall be used for all work in the sidewalk, drive apron, and curb and gutter area. All costs pertaining to the above work shall be at the Contractors expense.

SECTION 109.2 PROSECUTION OF THE WORK

The Contractor shall begin work for this project on or before **May 29, 2018**. Work shall begin only after the start work letter is received. If it is desirable to begin work before the above-mentioned date, the Contractor shall establish a mutually acceptable date with the City Engineer.

All work shall be completed on or before **November 30, 2018**.

The Contractor shall work such overtime as required by the Engineer to meet the requirements of this project at no additional cost to the City.

The time of completion will be computed in accordance with Section 109.7 of the Specifications starting with the latest start date shown above or the actual date work begins whichever is sooner.

- A. This contract shall be in force from the date of award to completion within the current calendar year. In the event that the Contractor fails to show an acceptable rate of progress, the Contractor will be notified in writing of such and have seven (7) calendar

days in which to resume work. Failure to respond to said notice, would subject the Contractor to paragraph C. of this section.

- B. The Contractor shall furnish a minimum of one (1) complete working crew in order to insure the completion of the work contemplated by this contract.

A complete working crew shall consist of at least the following personnel:

1. One Foreman
 2. One Cement Finisher
 3. Two Laborers for Concrete Work
 4. Grading force sufficient to prepare sufficient grade ahead of form setting and concrete work in order that concrete work shall not be delayed.
 5. Backfilling and cleanup force sufficient to restore disturbed areas within one (1) work day after the concrete is cured.
- C. There shall be deducted from any monies due or that may become due the Contractor, the sum of \$425.00 for each and every work day that the Contractor shall fail to provide the working forces as specified in paragraph B above. This sum shall be considered and treated not as a penalty but as fixed, agreed liquidated damages due the City of Madison from the Contractor by reason of inconvenience to the public, added costs of engineering and supervision, maintenance of detours and other items which have caused an expenditure of public funds resulting from his/her failure to comply with the requirements of paragraph A above.
- D. Where any deductions from or forfeitures of payment in connection with the work of this contract are duly and properly declared or imposed against the Contractor, in accordance with the terms of this contract, State Laws, or Ordinances of the City, the total amount thereof may be withheld from any money whatsoever due or to become due the Contractor under the contract, and when deducted, shall be deemed and taken as payment in such amount.
- E. A "Work Day" shall be any day that a Contractor can work on a project and it would or does necessitate an Engineer or Inspector on the project for any part of the day. If inclement weather curtails construction, the Engineer shall decide what portion, if any part of a day, shall be called a "Work Day". Work days may be counted to the nearest one-half day. A record of work days shall be kept on the job by the Engineer or Inspector.

SECTION 109.3 LIMITATIONS OF OPERATIONS

Sidewalk and driveway aprons in residential areas shall be replaced within three (3) work days after it has been made impassable or removed.

Sidewalk, driveways, and drive aprons adjoining multi-family units and business properties shall be replaced within twenty-four (24) hours after being made impassable or removed. This does not eliminate the requirement for maintaining driveway access to multi-family units and commercial properties at all times as described in Section 107.1 within these Special Provisions.

The Contractor shall properly barricade all work areas until all patching, topsoil, seed and matting work is completed.

SECTION 109.14 MOBILIZATION

This contract does not include a separate contract item for Mobilization. All the work herein before prescribed, required and performed will not be separately measured for payment, but will be considered incidental to other items in the contract.

SECTION 201 EXCAVATION CUT

The cost of excavating and preparation of subgrade including subbase, backfilling, and disposal of surplus materials shall be incidental to the new sidewalk Bid Items of 5-Inch Concrete Sidewalk and 7-Inch Concrete Sidewalk & Drive.

At locations where excavation is required at a depth greater than seven (7) inches for 5-Inch Concrete Sidewalk, the amount over seven inches shall be paid for at the unit price Excavation Cut and the difference to be backfilled shall be paid for at the unit price as Crushed Stone.

At locations where excavation is required at a depth greater than nine (9) inches for 7-Inch Concrete Sidewalk, the amount over nine inches shall be paid for at the unit price Excavation Cut and the difference to be backfilled shall be paid for at the unit price as Crushed Stone.

SECTION 210 EROSION CONTROL

Material stored at the project site, for use as backfill materials shall be stored in such a manner that will not result in runoff of stockpiled material into streets or drainage facilities in the event of rain. Excavated materials and imported backfill materials stored on street and sidewalks pavements shall be removed from the street and sidewalk pavements by hand shoveling and brooming at the end of each work day.

BID ITEM 20326-REMOVING FENCE

DESCRIPTION

This work shall consist of removing the existing chain link fence located at Fire Station #3, 1217 Williamson St, and disposing of the resulting materials.

The existing fence, with all parts and connections, shown on the plans to be removed, shall be entirely removed within the limits shown, or as directed by the engineer. No equipment or devices shall be used which might damage structures, facilities, or property which are to be preserved and retained:

METHOD OF MEASUREMENT

Work under this item shall be measured by length in lineal feet.

BASIS OF PAYMENT

This item, measured as described above, will be paid for at the contract price per lineal foot. This price shall be full compensation for furnishing all labor, tools, materials, equipment, and incidentals to complete the work.

BID ITEM 21041 – INLET PROTECTION, TYPE D – COMPLETE (UNDISTRIBUTED)

BID ITEM 21061 – EROSION MATTING, CLASS I, URBAN TYPE A (UNDISTRIBUTED)

DESCRIPTION

Inlet Protection Type D Complete and Erosion Matting, Class I, Urban Type A and any other erosion control measures shall be installed as directed by the Engineer.

SECTION 301.8 PROTECTION OF THE CONCRETE

The Contractor shall protect all concrete work subjected to cold weather. Protection of same shall be done in accordance with Madison Standard Specifications. The Contractor shall protect all concrete work against damage or defacement of any kind until it has been accepted by the City. Concrete not acceptable to the Engineer, shall be removed and replaced, or repaired to the satisfaction of the Engineer. All costs pertaining to the above work shall be at the Contractor's expense.

BID ITEM 30340 – CURB RAMP DETECTABLE WARNING FIELDS

MATERIALS

This section shall be revised to include The City of Madison shall furnish the Detectable Warning Fields.

The Contractor shall contact City of Madison Engineering Services, 1600 Emil Street, 608-266-4430, during regular business hours, a minimum of one working day in advance to schedule pick-up of the cast iron plates. The Contractor shall pick up the cast iron plates between the hours of 7:30 a.m. and 8:00 a.m.

SECTION 305.2 REMOVE & REPLACE 5 INCH CONCRETE SIDEWALK-SIDEWALK REPLACEMENT PROGRAM; REMOVE AND REPLACE 7 INCH CONCRETE SIDEWALK-SIDEWALK REPLACEMENT PROGRAM

DESCRIPTION

All sidewalk removed at crosswalks shall be replaced with 7 inches of concrete.

METHOD OF MEASUREMENT

Remove & Replace 7 Inch Concrete Sidewalk-Sidewalk Replacement Program shall be measured by the square foot.

BASIS OF PAYMENT

All sidewalk removed at crosswalks as provided above shall be paid for at the unit price of Remove & Replace 7 Inch Concrete Sidewalk-Sidewalk Replacement Program.

SECTION 305.5 REMOVE & REPLACE CONCRETE CURB & GUTTER-SIDEWALK REPLACEMENT PROGRAM

DESCRIPTION

The Contractor shall be responsible for maintenance of pavement adjacent to curb until resurfacing operations take place. This work shall be incidental to the operations connected with this bid item.

SECTION 402 ASPHALT CONSTRUCTION

Asphalt surface course, installed with this contract, shall conform to all the pertinent requirements of Section 402 of the Standard Specifications except as modified herein.

For temporary sidewalks, the mixture shall be installed to be one (1) inch in compacted thickness and to the width designated in the field by the Engineer. The existing base or foundation shall be leveled and mechanically compacted.

Patching along curb and gutter, driveways, sidewalks, and other areas shall be done at the locations and to dimensions and depths as laid out in the field by the Engineer. Tack coat shall be applied to all adjacent existing concrete and asphalt surfaces.

The unit price bid for HMA pavement shall include the cost of tack coat materials.

BID ITEM 40202 – HMA PAVEMENT 4 LT 58-28 S

METHOD OF MEASUREMENT

HMA Pavement 4 LT 28-28 S shall be measured by the area in square yard.

BID ITEM 90001 – HIGH EARLY STRENGTH CONCRETE, REMOVE AND REPLACE 7-INCH CONCRETE SIDEWALK AND DRIVEWAY – SIDEWALK REPLACEMENT PROGRAM

Work under this item shall be in accordance with Article 305 of the Standard Specifications, and as hereinafter provided.

The Contractor shall use high early strength concrete on driveways and sidewalks in areas designated by the Engineer.

BID ITEM 90002 – HIGH EARLY STRENGTH CONCRETE, REMOVE AND REPLACE CONCRETE CURB & GUTTER – SIDEWALK REPLACEMENT PROGRAM

Work under this item shall be in accordance with Article 305 of the Standard Specifications, and as hereinafter provided.

The Contractor shall use high early strength concrete on curb and gutter in areas designated by the Engineer.

BID ITEM 90003 – BUS PAD

DESCRIPTION

This item involves the construction of new 5 inch concrete bus pads at locations specified in these Special Provisions. Additional locations may be added. Madison Metro staff will mark specific bus pad locations on the curb.

METHOD OF PAYMENT

Bus Pad shall be measured by the area in square feet.

In cases where sidewalk is required to connect the bus pad to the mainline walk, it shall be paid in square feet under this item.

BASIS OF PAYMENT

The contact price for Bus Pad, measured as provided above, shall be payment in full for the work as outlined above, including: excavation, disposal of removed material; preparation of subgrade including subbase; for furnishing and placing 5 inch concrete sidewalk, finishing and protecting; fill, topsoil, seed and matting, and for all labor, tools, equipment and incidentals necessary to complete the work.

BID ITEM 90004 – C1 CONCRETE SIDEWALK, 7-INCH

DESCRIPTION

This work shall be in accordance with the requirements of Part 3 of the Standard Specifications, except as herein after amended.

MATERIALS

The concrete mix design shall be as follows per cubic yard:

Cement: 575 lbs

Fine Aggregate: 950 lbs

Upper Canadian Black Granite ($\frac{1}{2}$ x $\frac{1}{4}$) or Starlite Black Granite (9/16 x 3/16): 752.5 lbs

Colonial Red Granite (9/16 x 3/16): 1397.5 lbs

Sieve Analysis

Upper Canadian Black Granite

Sieve Size	% Passing
9/16"	100%
0.53"	98.5%
7/16"	84.7%
5/8"	65.8%
1/4"	14.2%
#4	1.0%

Starlite Black Granite

Sieve Size	% Passing
9/16"	98%
3/8"	66%
3/16"	12%
#8	0%

Colonial Red Granite

Sieve Size	% Passing
9/16"	98.0%
3/8"	67.0%
#4	13.0%
#8	3.0%
#16	<1.0%

Expansion joint filler shall be closed cell foam type conforming to ASTM D 1752. ASTM D 5249, Type 412, ASTM D 7174. The joint sealer shall be the gun grade Sonolastic NP 1 urethane as manufactured by Sonneborn, or an approved equal. The color shall match the adjoining work and shall be approved by the Engineer.

CONSTRUCTION

Placing and Finishing Concrete. Conform to Part 3 of the Standard Specifications for the concrete. The Engineer will check and approve the foundation, forms and reinforcement if required, before placing the concrete. Place the concrete on a moist foundation, deposit it to the required depth, and consolidate sufficiently to bring the mortar to the surface, then strike-off and finish to a true and even surface. Before mortar sets, spray the surface with water and brush or lightly broom the surface to expose the aggregate to closely match the existing C1 concrete sidewalk adjacent to the area. Before performing the final surface finish, check the sidewalk surface with a 10-foot straightedge, and correct all areas that vary $\frac{1}{4}$ -inch from the testing edge by adding or removing concrete while the concrete is still plastic.

C1 Concrete Sidewalk 7-Inch shall be doweled into all existing and new concrete with #6 epoxy coated tie bars. All tie bars shall be in accordance with Standard Details 3.10 and 3.11 of the City of Madison Standard Specifications

All C1 Concrete Sidewalk 7-Inch shall include 2 inches crushed stone base foundation incidental if needed.

Contractor shall follow concrete waste management specifications as outlined in section 301.10 of the Standard Specifications for Public Works Construction.

METHOD OF MEASUREMENT

C1 Concrete Sidewalk 7-Inch shall be measured by the area in square foot installed and accepted.

BASIS OF PAYMENT

C1 Concrete Sidewalk 7-Inch, measured as stated above, is full compensation for providing all materials, including concrete, cardboard void forms, bar steel reinforcement HS, joint fillers, joint sealers, and expansion joints; for excavating and preparing the foundation; backfilling and disposing of surplus material; for placing, finishing, protecting, and curing; and restoring the work site.

BID ITEM 90005 – REMOVE & REPLACE 7" CONCRETE DRIVEWAY-FIRE STATION #3

DESCRIPTION

Work under this item shall consist of removing and replacing the existing concrete driveway at Madison Fire Station #3, located at 1217 Williamson St, where designated by the Engineer in accordance with section 303.3 of The City of Madison Standard Specifications except as modified herein.

Removal and replacement of the concrete driveway shall include all costs for sawcutting existing concrete, excavating, replacement of sub-base material with six inches (6") of 1 1/4" crushed stone or crushed concrete as needed, grade preparation, forming, and placing concrete, including integral curb head, and installation of epoxy coated pavement ties.

The cost of placing and compacting select backfill shall be incidental to this item.

Transverse full depth sawcuts shall be incidental to the removal item.

METHOD OF MEASUREMENT

Work under this item shall be measured by area in square feet completed and accepted.

BASIS OF PAYMENT

This item, measured as described above, will be paid for at the contract price per square foot. This price shall be full compensation for furnishing all labor, tools, materials, equipment, and incidentals to complete the work.

2018 CITYWIDE DEFECT DATA

Zip	Address	Frontage	Type of Defect	R&R 5" Sidewalk (SF)	R&R 7" Sidewalk (SF)	New Sidewalk (SF)	Detectable Warning Fields (SF)	Bus Pad (SF)	Conc. Pymt. Reconstruct (SV)	R&R C&G (LF)	Comments
53562	9418 Eagle Nest Ln	Eagle Nest Ln	Sidewalk	53							
53703	1234 E Dayton St	E Dayton St	Sidewalk	107							
53703	802 E Gorham St	E Gorham St	Bus Pad		100		8	80		12	Warranty work from 2012**need to mark** N SIDE OF E GORHAM, E OF N LIVINGSTON; RAMP, KEYSTONE, X-CURB, EXTEND BUS PAD 6'
53703	902 E Gorham St	E Gorham St	Bus Pad	120							N SIDE OF E GORHAM, E OF N PATTERSON; REMOVE/REPLACE EXISTING PAD
53703	110 S Henry St	W Main St	Ramp		40		8	80			Ramp at the corner of W Main St/S Henry St
53703	1110 Jennifer St	Jennifer St	Bus Pad								N SIDE OF E JOHNSON ST, W OF N SIXTH ST, BUS PAD ONLY, THIS IS TENTATIVE PER METRO
53703	2 E Mifflin St	Wisconsin Ave	Ramp		38		8				corner of Wisconsin @ E Dayton
53703	502 State St	W Gilman St	Sidewalk	42							CI Exposed Agg.
53703	506 State St	State St	7" CI Sidewalk		40						CI Exposed Agg., actual location at 513 State
53703	507 State St	State St	7" CI Sidewalk		40						CI Exposed Agg.
53703	514 State St	State St	7" CI Sidewalk		120						CI Exposed Agg.
53703	652 State St	State St	7" CI Sidewalk		50						CI Exposed Agg.
53703	501 E Washington Ave	S Blair St	Sidewalk	40							Old Tree Grate abandonment
53703	1138 Williamson St	Williamson St	Sidewalk	133							Repair sidewalk installed in 2011 with Williamson St reconstruction. Contact Forestry for tree concerns
53703	1140 Williamson St	Williamson St	Sidewalk	101							Repair sidewalk installed in 2011 with Williamson St reconstruction. Contact Forestry for tree concerns
53703	1143 Williamson St	Williamson St	Sidewalk	25							Repair sidewalk installed in 2011 with Williamson St reconstruction. Contact Forestry for tree concerns
53703	1217 Williamson St	Williamson St	Sidewalk	96							Sidewalk along NE side of building, adjacent to Willy St Coop Parking Lot.
53703	1217 Williamson St	Williamson St	7" Conc. Driveway		2325					13	Driveway along SW side/back of building. Includes 135' integral C&G snow covered, not marked
53704	1509 Arizona Pass	Arizona Pass	Curb							10	
53704	2033 Atwood Ave	Atwood Ave	Curb		30						
53704	3655 Kinsman Blvd	Kinsman Blvd	Bus Pad					80			N SIDE OF KINSMAN BLVD, W OF N STOUGHTON RD; BUS PAD ONLY
53704	3699 Kinsman Blvd	Kinsman Blvd	Bus Pad					80			S SIDE OF KINSMAN BLVD, W OF N STOUGHTON RD; BUS PAD ONLY
53704	4110 Melody Ln	Melody Ln	WaterWay			24					waterway
53704	1423 Northport Dr	Troy Dr	Sidewalk	72							**Electric and Sewer are also to be installed at this same location(MGE & PO were on site at time)**
53704	549 Oak St	Oak St	Bus Pad					80			E SIDE OF OAK ST, S OF COMMERCIAL AVE; BUS PAD ONLY
53704	3309 Portage Rd	Portage Rd	Curb							18	**Not Marked**
53704	1848 Rutledge St	Rutledge St	Terrace Walk			24					WaterWay, may need to do some terrace grading after**need to mark**
53704	2102 Sherman Ave	Sherman Ave	Bus Pad					80			W SIDE OF SHERMAN AVE, N OF HARBORT DR; BUS PAD ONLY
53704	222 N Sixth St	E Johnson St	Bus Pad					80			S SIDE OF E JOHNSON ST, W OF N SIXTH ST, BUS PAD ONLY
53704	2498 Sloan Blvd	Sloan Blvd	Sidewalk	135							Water main break in sidewalk behind building at 3113 Mitchell St. Inside the boundary of Air National Guard Base.
53705	402 N Franklin Ave	N Franklin Ave	Ramp		81		16				2 ramps at same corner
53705	4721 Regent St	Regent St	WaterWay			24					Waterway
53705	5205 Shawano Ter	Shawano Ter	WaterWay			24					WATERWAY
53705	5209 Shawano Ter	Shawano Ter	WaterWay			24					Waterway
53706	821 University Ave	University Ave	Terrace Walk								
53706	970 University Ave	University Ave	9" Concrete Pavement Patch						90		this is in the North driving lane and the bike lane, East of N. Charter St**not marked**
53711	2459 Commonwealth Ave	Commonwealth Ave	Bus Pad					50			E SIDE OF COMMONWEALTH AVE, S OF GREGORY ST; EXTEND PAD 6'
53711	5201 Kroncke Dr	Tawhee Dr	WaterWay			24					2 waterways total
53711	5738 Kroncke Dr	Kroncke Dr	WaterWay			24					waterway
53711	502 Leonard St	Commonwealth Ave	Bus Pad								E SIDE OF COMMONWEALTH AVE, S OF LEONARD ST; EXTEND PAD 6'

2018 CITYWIDE DEFECT DATA

Zip	Address	Frontage	Type of Defect	R&R 5" Sidewalk (SF)	R&R 7" Sidewalk (SF)	New Sidewalk (SF)	Detectable Warning Fields (SF)	Bus Pad (SF)	Conc. Pmnt. Reconstruct (SY)	R&R C&G (LF)	Comments
53711	4325 Nakoma Rd	Nakoma Rd	Bus Pad					50			E SIDE OF NAKOMA RD, N OF MOHAWK DR; ADD 10'X6' PAD BEHIND WALK
53711	633 S Segoe Rd	Dearholt Rd	Curb							21	
53711	2323 Tanager Trl	Leland Dr	WaterWay			24					waterway
53711	2501 Westbrook Ln	Pilgrim Rd	WaterWay			24					waterway
53713	504 E Badger Rd	Rimrock Rd	Bus Pad					60			E SIDE OF RIMROCK, N OF E BADGER RD; ADD 10'X6' PAD BEHIND WALK
53713	1510 Lake Point Dr	Waumona Woods Ct	Curb							26	2 separate locations-11' + 14.5'
53713	2413 S Park St	S Park St	9" Concrete Pavement Patch						28		
53714	222 Harding St	Harding St	Curb							23	
53714	515 Pinney St	Pinney St	Curb							23	Southeast corner of Pinney St/Reyster Oaks Dr.
53714	117 Rosemary Ave	Rosemary Ave	Ramp		20	8					
53714	117 Rosemary Ave	Rosemary Ave	Curb							8	**need to mark, can't see**
53715	1111 Gilson St	Gilson St	Sidewalk	55							**PENDING BPW APPROVAL** Hold until further notice. D13-2021
53715	907 S Park St	S Park St	9" Concrete Pavement Patch						25	20	
53716	4726 E Broadway	E Broadway	Curb							36	
53717	901 N Westfield Rd	Harvest Hill Rd	Sidewalk	53							
53719	21 Ariel Cir	Ariel Cir	Curb							8	
53719	6801 Avalon Ln	Avalon Ln	Curb							8	
53719	6802 Avalon Ln	Avalon Ln	Curb							8	
53719	7129 Birchstone Dr	Birchstone Dr	Curb							8	
53719	1 Bradbury Ct	Bradbury Ct	Curb							40	
53719	3402 Dorchester Way	Dorchester Way	Curb							6	
53719	1 Elmwood Ct	Elmwood Ct	Curb							8	
53719	3802 Frosted Leaf Dr	Frosted Leaf Dr	Curb							10	
53719	9 Grove Cir	Grove Cir	Curb							30	
53719	7233 Heather Glen Dr	Heather Glen Dr	Curb							12	
53719	3609 Ice Age Dr	Ice Age Dr	Curb							8	
53719	3429 Kingman Ln	Kingman Ln	Curb							10	
53719	5 Laredo Ct	Laredo Ct	Curb							15	
53719	3501 Mammoth Trl	Mammoth Trl	Curb							10	
53719	3929 Mammoth Trl	Mammoth Trl	Curb							10	
53719	14 Marble Cir	Marble Cir	Curb							6	
53719	7429 North Pass	North Pass	Curb							10	
53719	1 Payson Ct	Payson Ct	Curb							10	
53719	10 Prescott Cir	Prescott Cir	Curb							40	
53719	10 Rudi Cir	Rudi Cir	Curb							10	
53719	10 Snowflake Ct	Snowflake Ct	Curb							6	

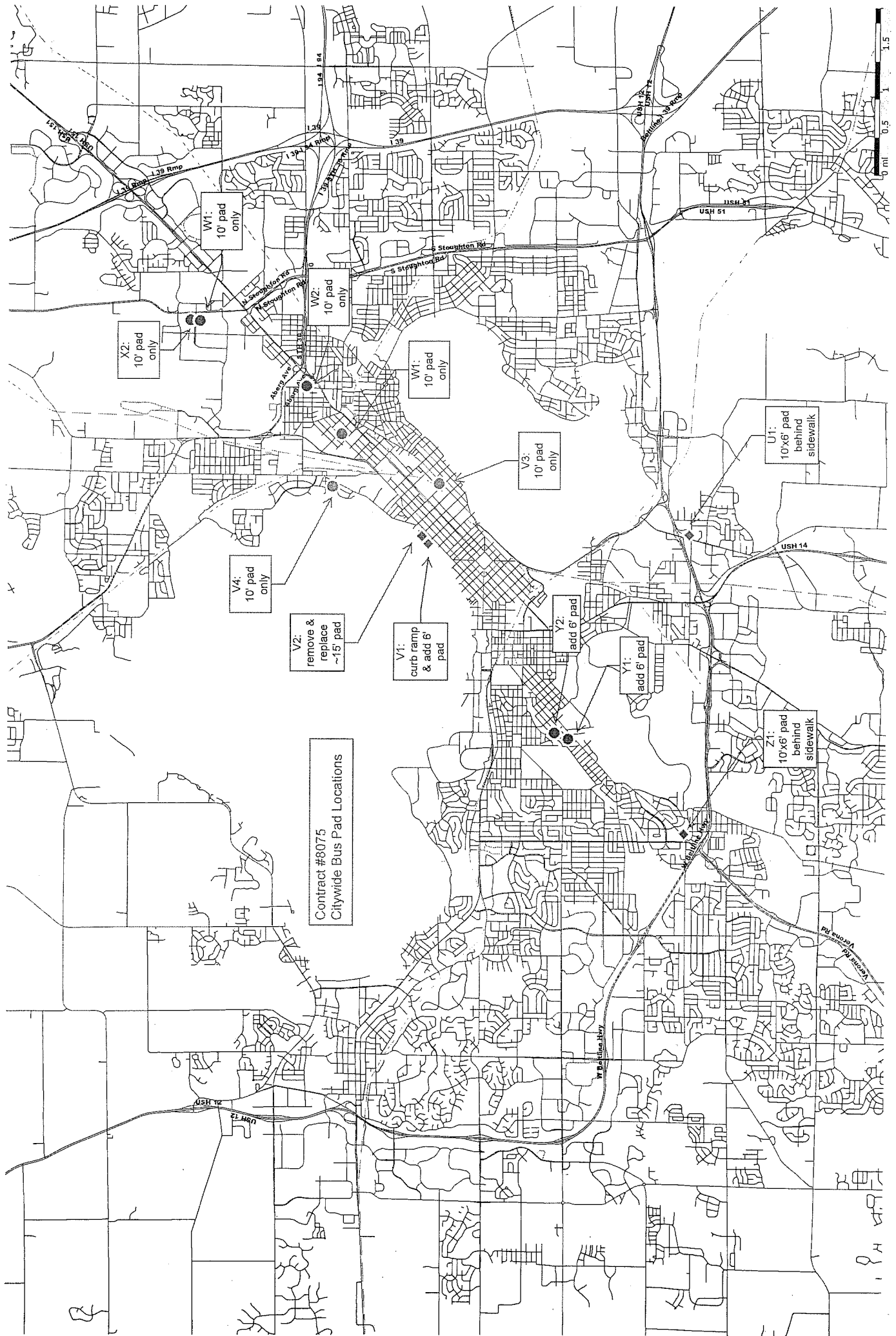

**Contract #8075
Citywide Bus Pad Locations**

W1:
10' pad
only

W2:
10' pad
only

W1:
10' pad
only

X2:
10' pad
only

V4:
10' pad
only

V2:
remove &
replace
& add 6'
~15' pad

V1:
curb ramp
& add 6'
pad

V3:
10' pad
only

Y2:
add 6' pad

Y1:
add 6' pad

Z1:
10x6' pad
behind
sidewalk

U1:
10x6' pad
behind
sidewalk



MAP	BLOCK	LOCATION	COMMENTS	DIS
U1	504 E Badger Rd	E side of Rimrock Rd, N of E Badger Rd	Add pad behind walk	E
V1	802 E Gorham St	N side of E Gorham, E of N Livingston	Ramp + extend pad	E
V2	902 E Gorham St	N side of E Gorham, E of N Paterson	Remove/replace pad	E
V3	1110 Jenifer St	N side of Jenifer St, E of N Ingersoll St	Bus pad only	E
V3	2102 Sherman Av	W side of Sherman Av, N of Harbort Dr	Bus pad only	E
W1	222 N Sixth St	S side of E Johnson St, W of N Sixth St	Bus pad only	E
W2	549 Oak St	E side of Oak St, S of Commercial Av	Bus pad only	E
X1	3699 Kinsman Bl	S side of Kinsman Bl, W of N Stoughton Rd	Bus pad only	E
X2	3656 Kinsman Bl	N side of Kinsman Bl, W of N Stoughton Rd	Bus pad only	E
Y1	2459 Commonwealth Av	E side of Commonwealth Av, S of Gregory St	Extend pad	W
Y2	502 Leonard St	E side of Commonwealth Av, S of Leonard St	Extend pad	W
Z1	4325 Nakoma Rd	E side of Nakoma Rd, N of Mohawk Dr	Add pad behind walk	W

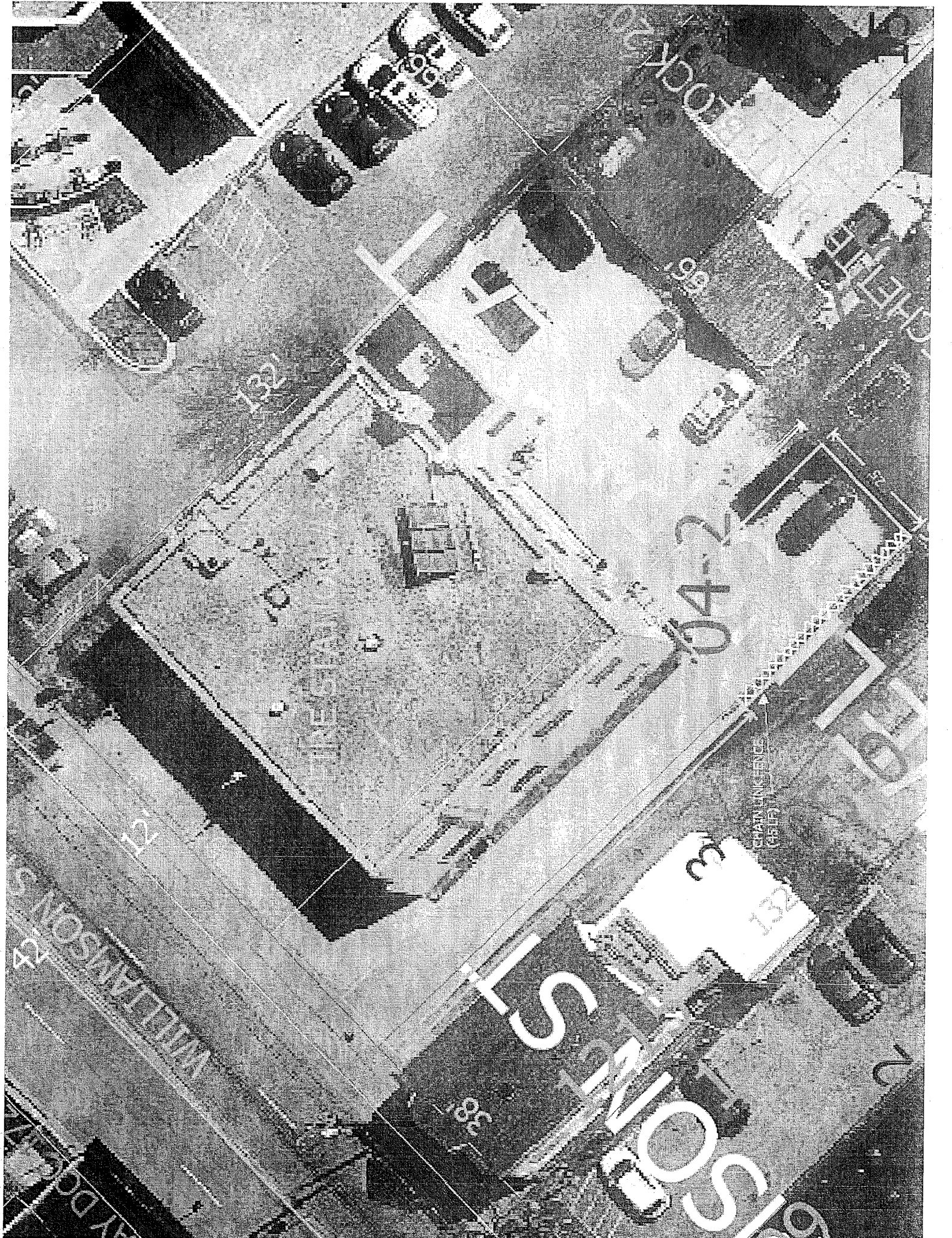

Fire Station #3
1217 Williamson St
Concrete Driveway/Integral Curb Detail

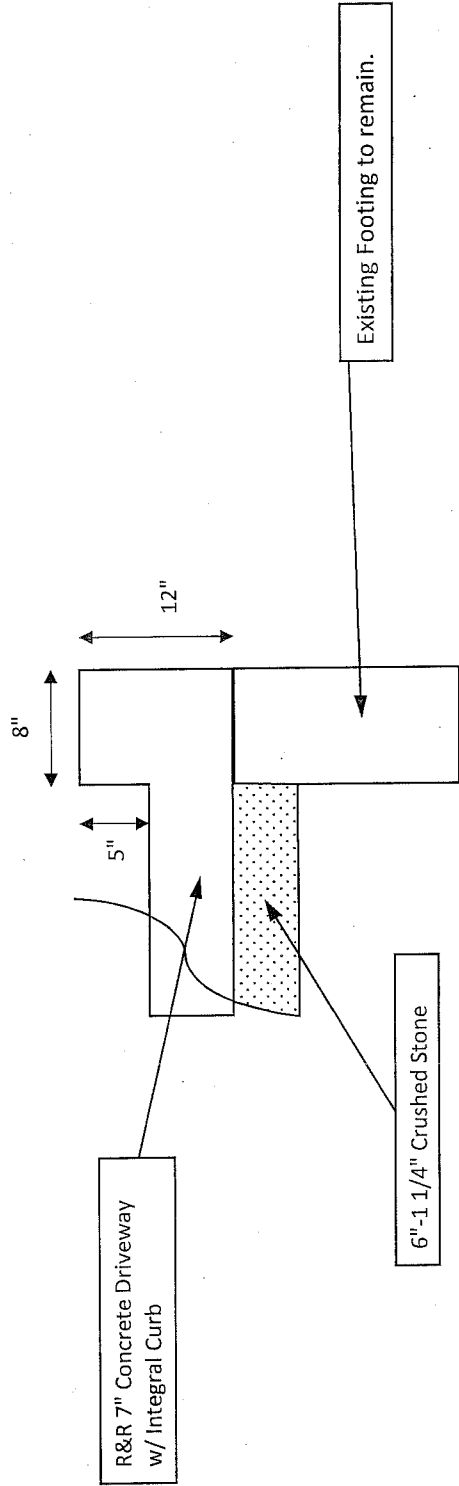

Drawing Not to Scale

8975

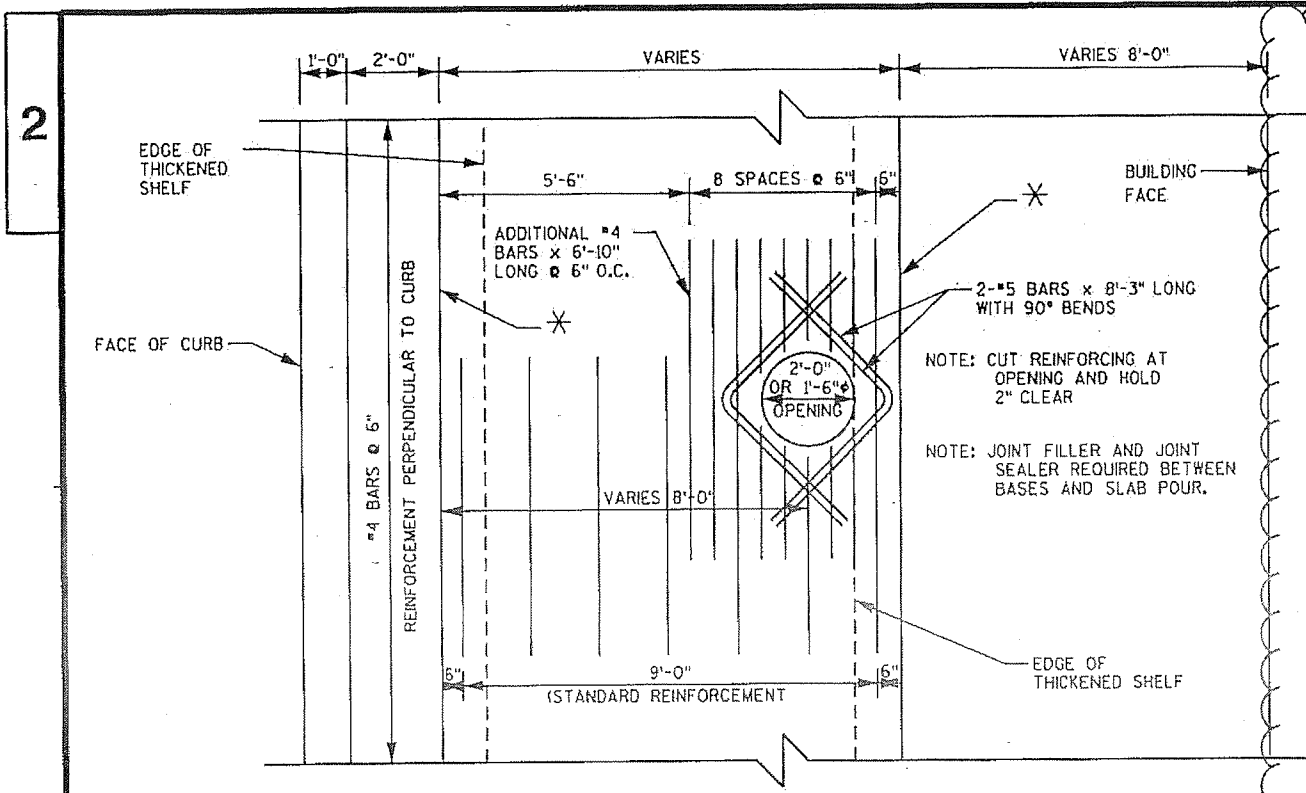

REINFORCEMENT PLAN - LIGHT BASE OPENINGS

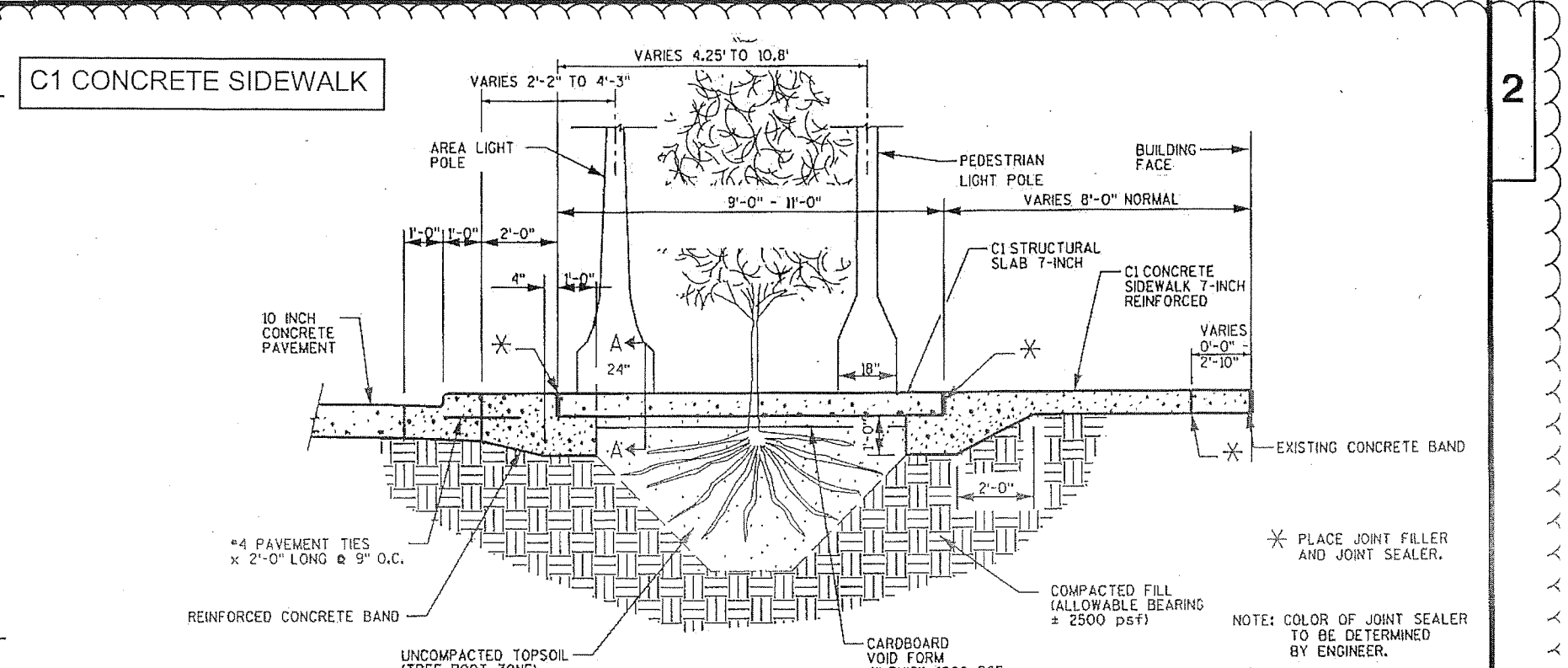

ROOT ZONE DETAIL

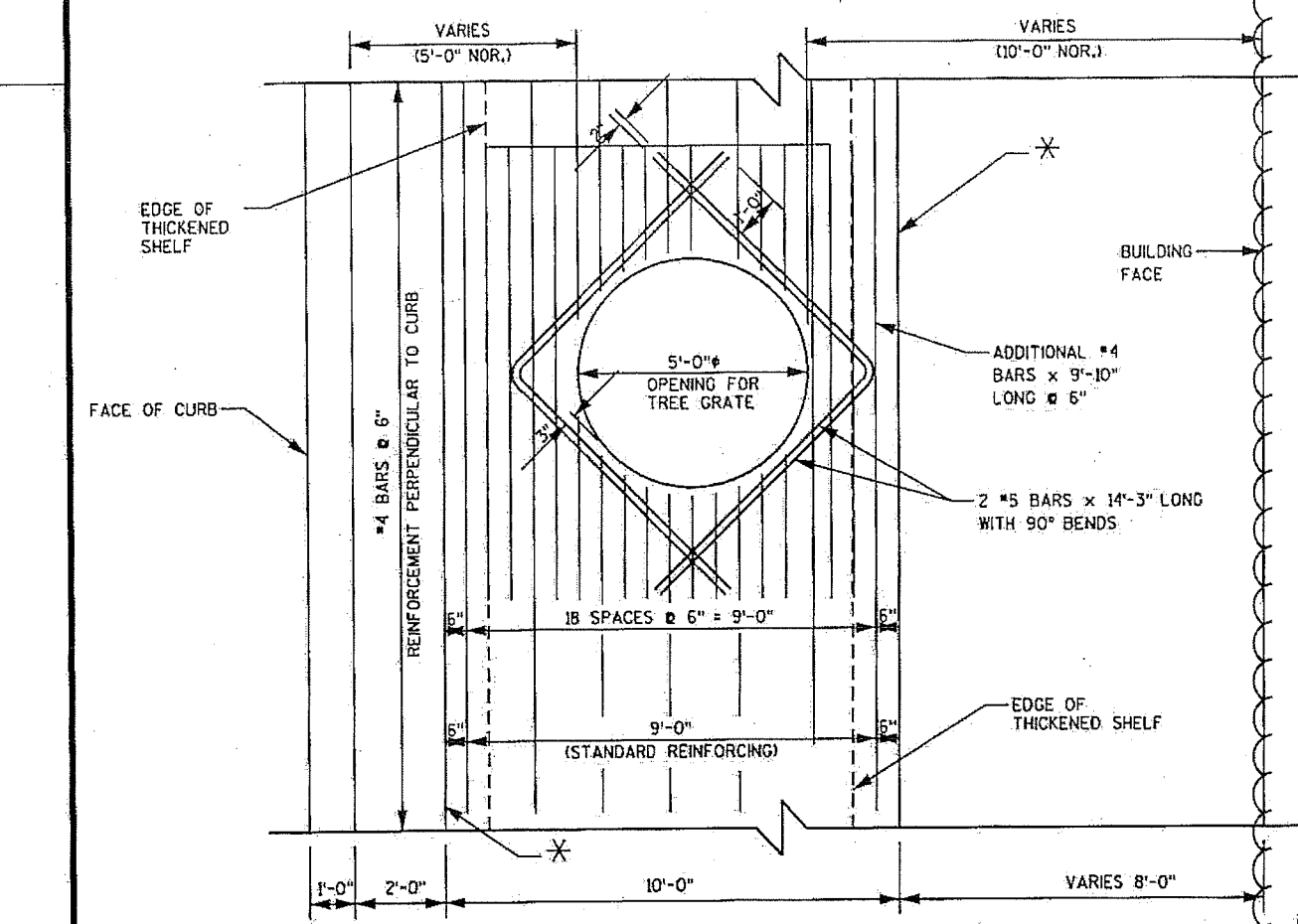

REINFORCEMENT PLAN - TREE OPENINGS

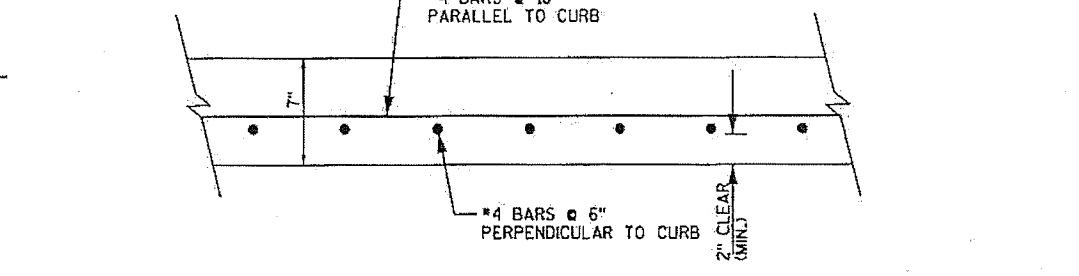

SECTION A-A, C1 STRUCTURAL SLAB 7-INCH REINFORCEMENT

NOTE: THIS CONFIGURATION MAY BE REPLACED AT THE CONTRACTOR'S DISCRETION BY WELDED WIRE FABRIC MESH HAVING AN EQUIVALENT OR GREATER AREA OF STEEL IN EACH DIRECTION, IN THAT CASE, ADDITIONAL BARS MUST BE ADDED AT SLAB OPENINGS AS SHOWN IN REINFORCEMENT PLAN DETAILS

POSSIBLE EQUIVALENT MESH CONFIGURATIONS INCLUDE:

- WWF 6x12 W18xW14;
- WWF 6x6 W18xW6;
- WWF 6x18 W18xW18;
- WWF 9x18 W26xW18

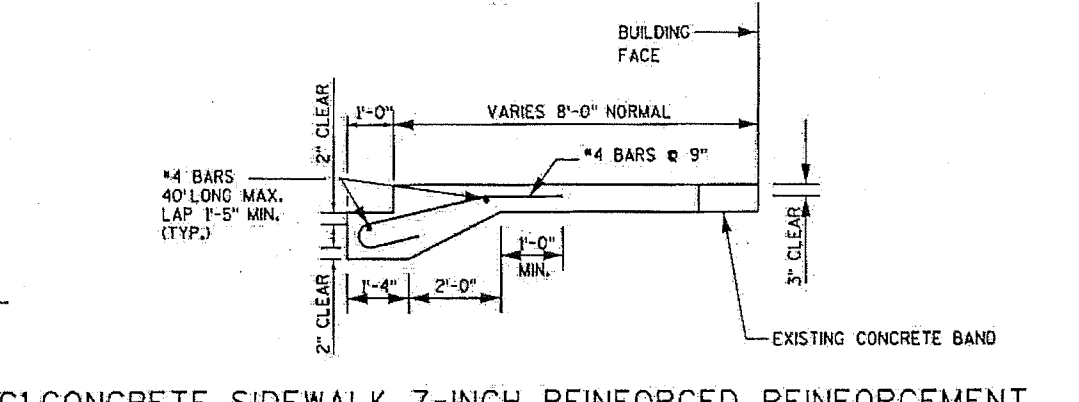

C1 CONCRETE SIDEWALK 7-INCH REINFORCED REINFORCEMENT

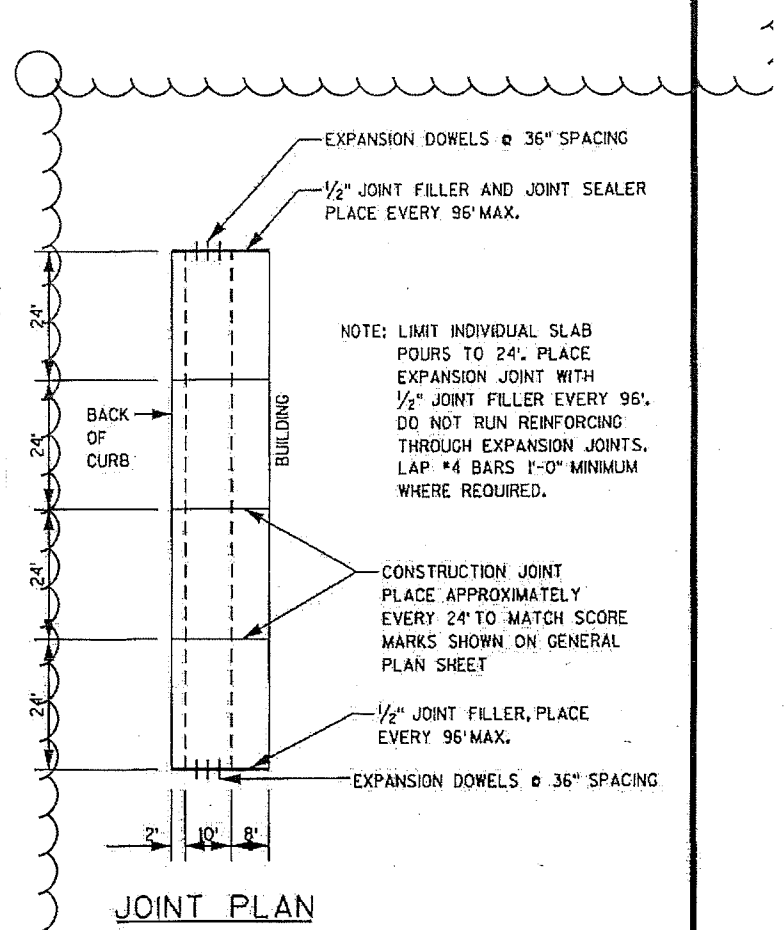

JOINT PLAN

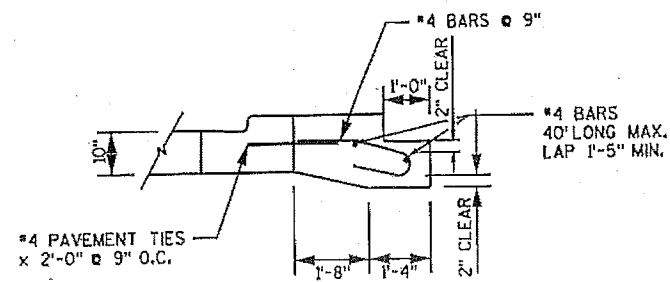

REINFORCED CONCRETE BAND

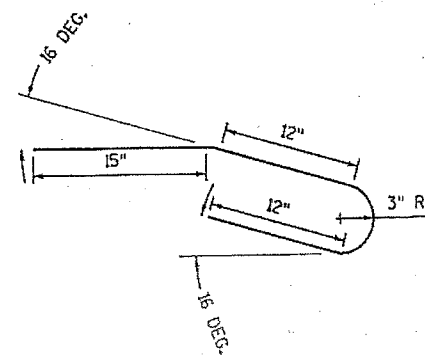

REINFORCED CONCRETE BAND REINFORCEMENT

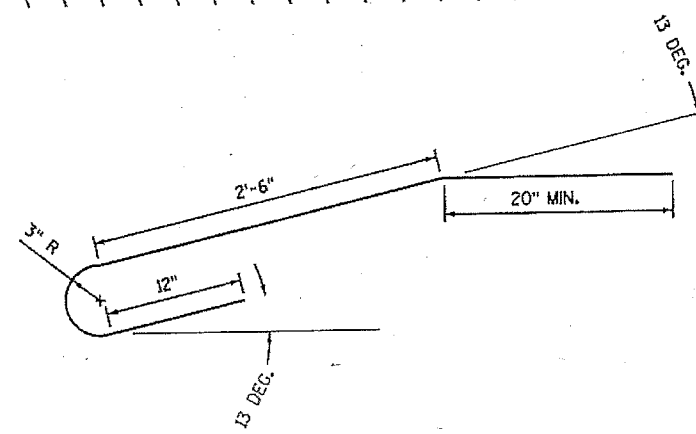

C1 CONCRETE SIDEWALK 7-INCH REINFORCED REINFORCEMENT

BAR BEND DETAILS

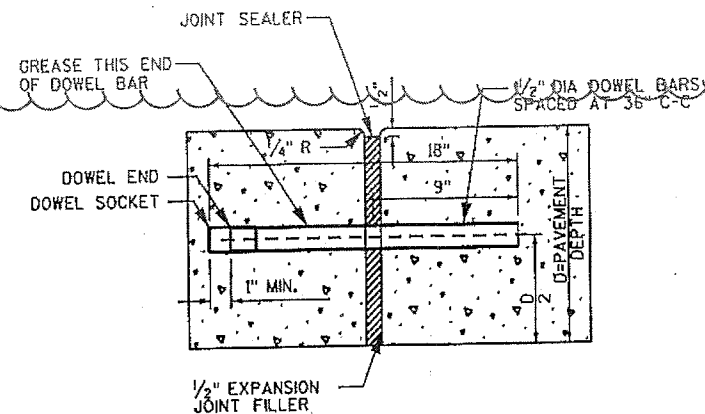

EXPANSION DOWELS

C1 CONCRETE SIDEWALK

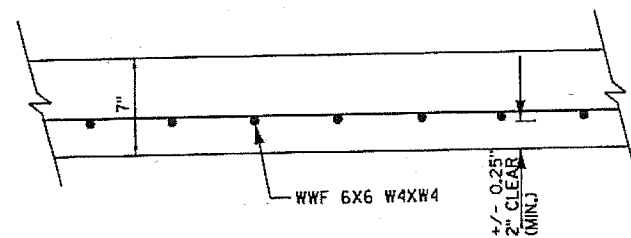

C1 CONCRETE SIDEWALK 7-INCH MESH REINFORCED

(SEE SIDEWALK PAVING DETAILS FOR LOCATION)

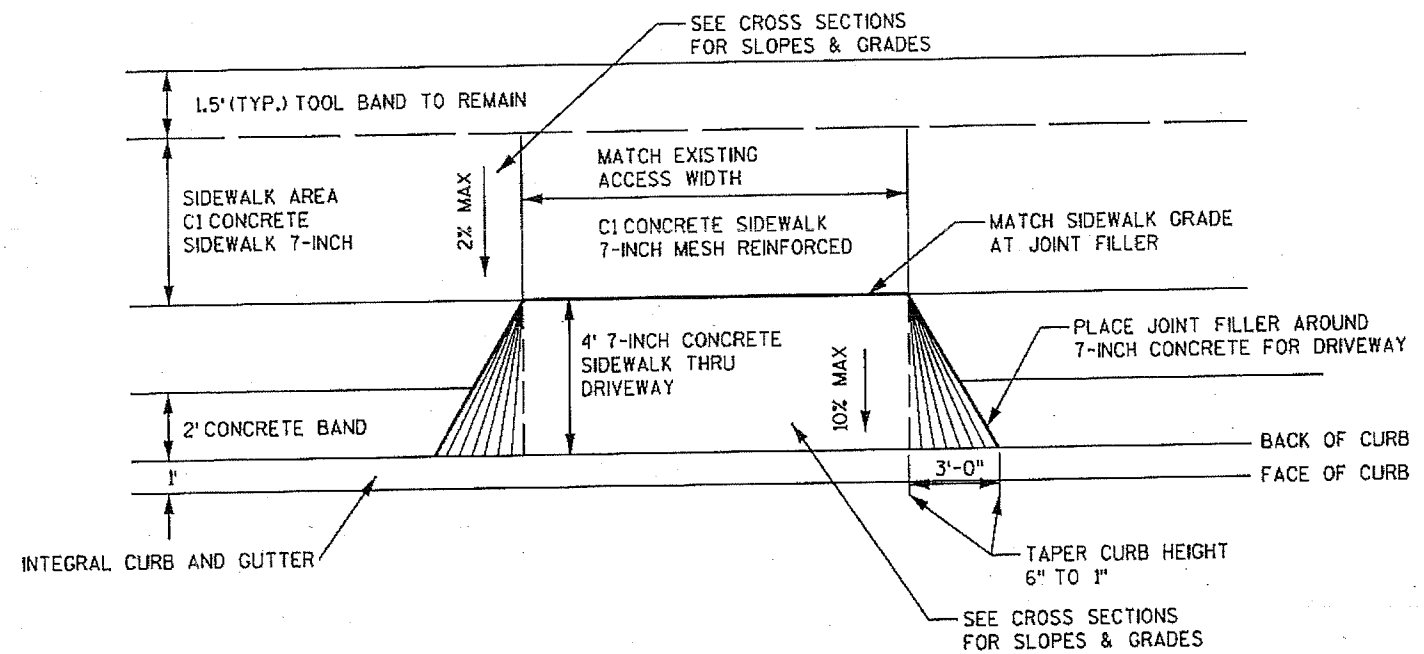

DRIVEWAY DETAIL

STA. 9+21
STA. 14+32



C1 CONCRETE SIDEWALK
REPAIR LOCATIONS

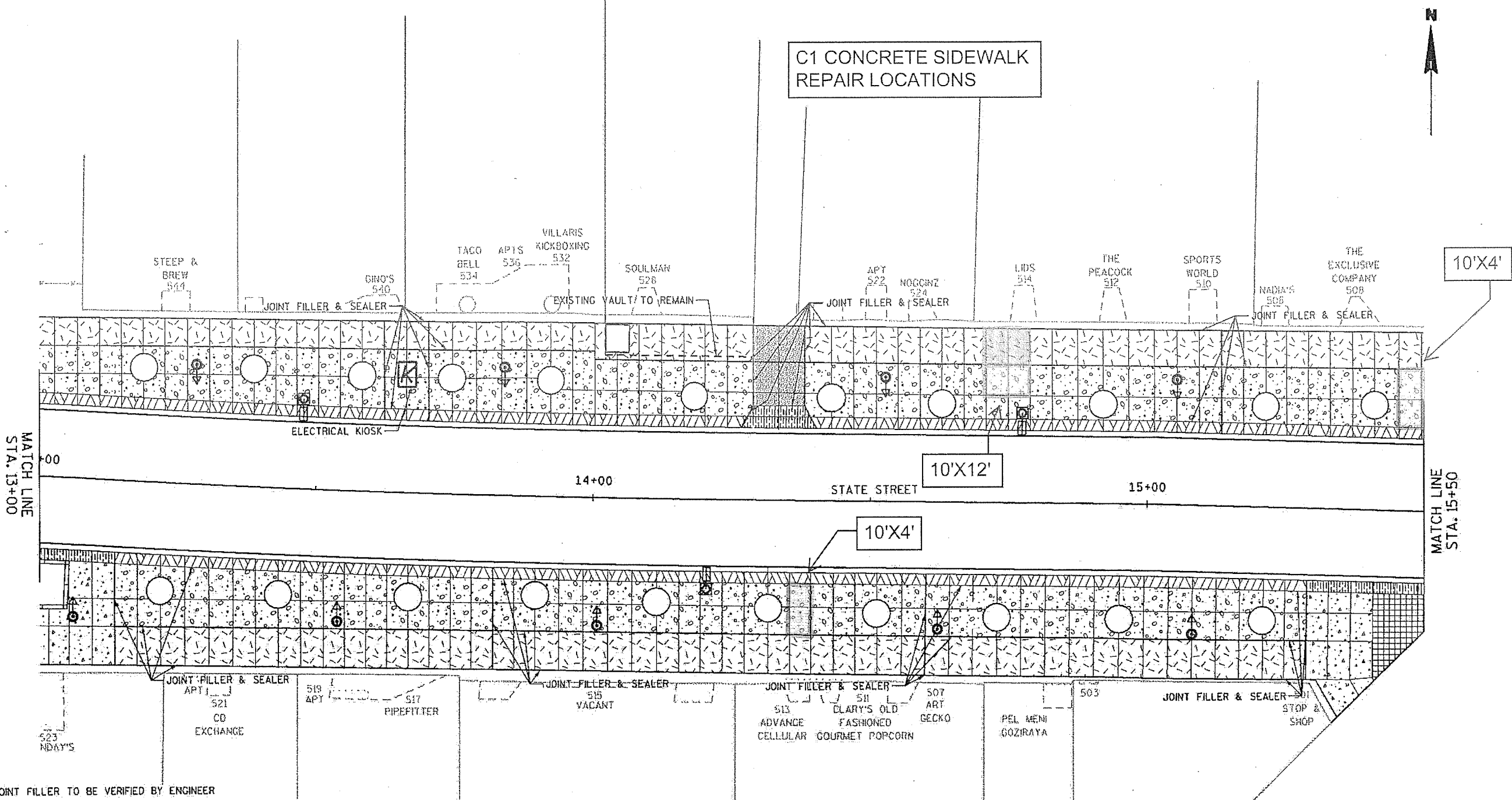

NOTE: COLOR OF JOINT FILLER TO BE VERIFIED BY ENGINEER

LEGEND

	REINFORCED CONCRETE BAND		7-INCH CONCRETE SIDEWALK		AREA LIGHT POLE
	C1 CONCRETE SIDEWALK 7-INCH REINFORCED		C1 STRUCTURAL SLAB 7-INCH		- FIXTURE
	C1 CONCRETE SIDEWALK 7-INCH		GRANITE PAVERS		- BASE
	C1 CONCRETE SIDEWALK 7-INCH MESH REINFORCED		C1 BUS SHELTER SLAB 8-INCH REINFORCED		PEDESTRIAN LIGHT POLE
					- FIXTURE
					- BASE
					TREE GRATE TYPE A

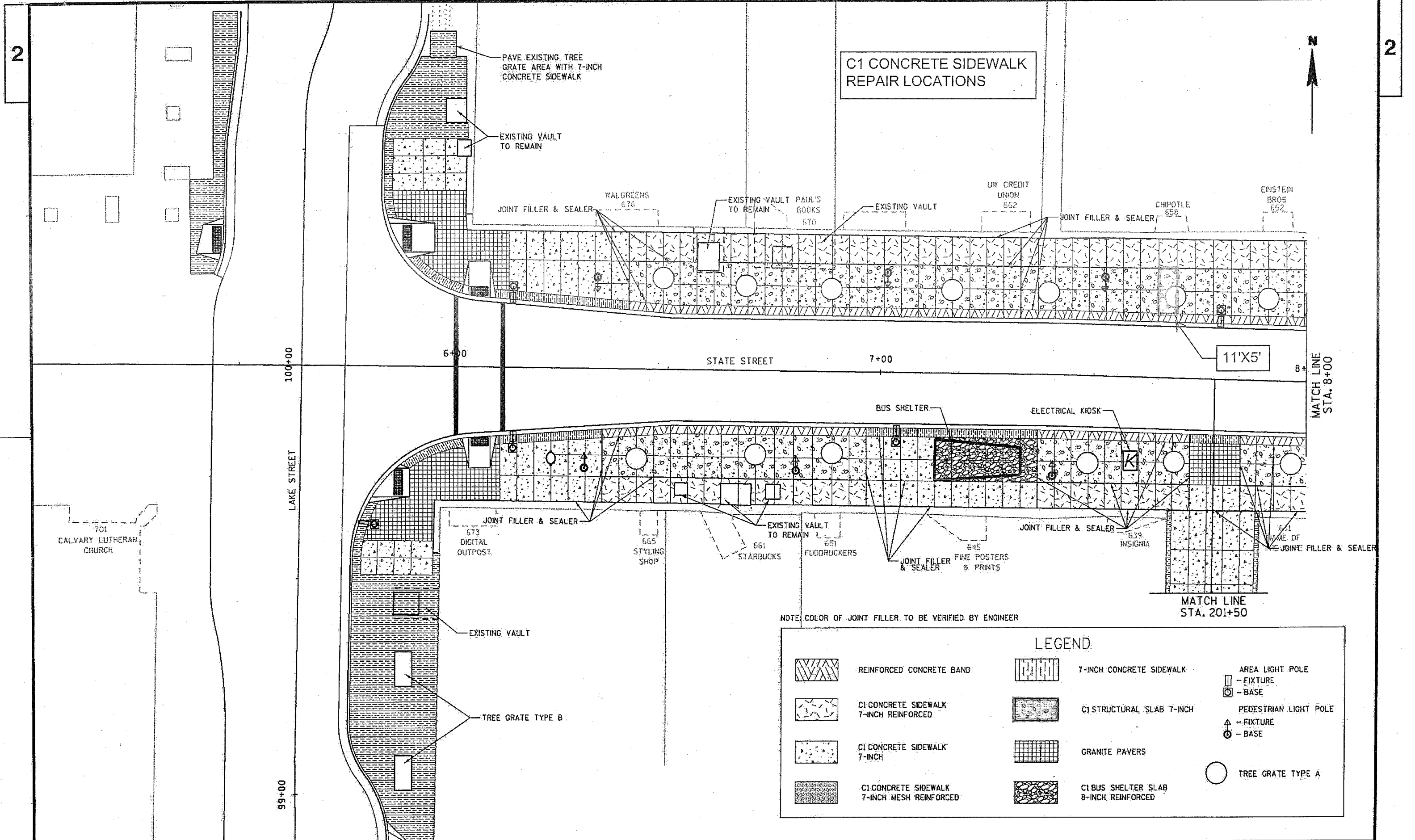

C1 CONCRETE SIDEWALK
REPAIR LOCATIONS

NOTE: COLOR OF JOINT FILLER TO BE VERIFIED BY ENGINEER

LEGEND			
	REINFORCED CONCRETE BAND		7-INCH CONCRETE SIDEWALK
	C1 CONCRETE SIDEWALK 7-INCH REINFORCED		C1 STRUCTURAL SLAB 7-INCH
	C1 CONCRETE SIDEWALK 7-INCH		GRANITE PAVERS
	C1 CONCRETE SIDEWALK 7-INCH MESH REINFORCED		C1 BUS SHELTER SLAB 8-INCH REINFORCED
			AREA LIGHT POLE - FIXTURE - BASE
			PEDESTRIAN LIGHT POLE - FIXTURE - BASE
			TREE GRATE TYPE A

SECTION E: BIDDERS ACKNOWLEDGEMENT

SIDEWALK, CURB & GUTTER AND CONCRETE PAVEMENT PATCHES, CITYWIDE
INSTALLATION AND REPAIR – 2018
CONTRACT NO. 8075

Bidder must state a Unit Price and Total Bid for each item. The Total Bid for each item must be the product of quantity, by Unit Price. The Grand Total must be the sum of the Total Bids for the various items. In case of multiplication errors or addition errors, the Grand Total with corrected multiplication and/or addition shall determine the Grand Total bid for each contract. The Unit Price and Total Bid must be entered numerically in the spaces provided. All words and numbers shall be written in ink.

1. The undersigned having familiarized himself/herself with the Contract documents, including Advertisement for Bids, Instructions to Bidders, Form of Proposal, City of Madison Standard Specifications for Public Works Construction - 2018 Edition thereto, Form of Agreement, Form of Bond, and Addenda issued and attached to the plans and specifications on file in the office of the City Engineer, hereby proposes to provide and furnish all the labor, materials, tools, and expendable equipment necessary to perform and complete in a workmanlike manner the specified construction on this project for the City of Madison; all in accordance with the plans and specifications as prepared by the City Engineer, including Addenda Nos. _____ through _____ to the Contract, at the prices for said work as contained in this proposal. (Electronic bids submittals shall acknowledge addendum under Section E and shall not acknowledge here)
2. If awarded the Contract, we will initiate action within seven (7) days after notification or in accordance with the date specified in the contract to begin work and will proceed with diligence to bring the project to full completion within the number of work days allowed in the Contract or by the calendar date stated in the Contract.
3. The undersigned Bidder or Contractor certifies that he/she is not a party to any contract, combination in form of trust or otherwise, or conspiracy in restraint of trade or commerce or any other violation of the anti-trust laws of the State of Wisconsin or of the United States, with respect to this bid or contract or otherwise.
4. I hereby certify that I have met the Bid Bond Requirements as specified in Section 102.5. (IF BID BOND IS USED, IT SHALL BE SUBMITTED ON THE FORMS PROVIDED BY THE CITY. FAILURE TO DO SO MAY RESULT IN REJECTION OF THE BID).
5. I, hereby certify that all statements herein are made on behalf of Raymond P. Cattell, Inc. (name of corporation, partnership, or person submitting bid) a corporation organized and existing under the laws of the State of WISCONSIN a partnership consisting of _____; an individual trading as _____; of the City of MADISON State of WISCONSIN; that I have examined and carefully prepared this Proposal, from the plans and specifications and have checked the same in detail before submitting this Proposal; that I have fully authority to make such statements and submit this Proposal in (its, their) behalf; and that the said statements are true and correct.

[Signature]
SIGNATURE

SECRETARY
TITLE, IF ANY

Sworn and subscribed to before me this
12TH day of APRIL, 2018.

[Notary Seal]
(Notary Public or other officer authorized to administer oaths)
My Commission Expires 1/26/22

Bidders shall not add any conditions or qualifying statements to this Proposal.

Section F: Best Value Contracting (BVC)

This section is a required document for the bid to be considered complete. There are two methods for completing the Best Value Contracting (BVC) form. Method one: The form can be filled out online and submitted to this site to be included with your electronic bid. Method two: The form can be downloaded from the site and submitted by hand to the City of Madison.

Method of Submittal for BVC (click in box below to choose) *

I will submit Bid Express fillable online form (BVC).

Best Value Contracting

1. The Contractor shall indicate the non-apprenticeable trades used on this contract.

2. Madison General Ordinance (M.G.O.), 33.07(7), does provide for some exemptions from the active apprentice requirement. Apprenticeable trades are those trades considered apprenticeable by the State of Wisconsin. Please check applicable box if you are seeking an exemption.

- Contractor has a total skilled workforce of four or less individuals in all apprenticeable trades combined.
- No available trade training program; The Contractor has been rejected by the only available trade training program, or there is no trade training program within 90 miles.
- Contractor is not using an apprentice due to having a journey worker on layoff status, provided the journey worker was employed by the contractor in the past six months.
- First time contractor on City of Madison Public Works contract requests a onetime exemption but intends to comply on all future contracts and is taking steps typical of a "good faith" effort.
- Contractor has been in business less than one year.
- Contractor doesn't have enough journeyman trade workers to qualify for a trade training program in that respective trade.
- An exemption is granted in accordance with a time period of a "Documented Depression" as defined by the State of Wisconsin.

3. The Contractor shall indicate on the following section which apprenticeable trades are to be used on this contract. Compliance with active apprenticeship, to the extent required by M.G.O. 33.07(7), shall be satisfied by documentation from an applicable trade training body; an apprenticeship contract with the Wisconsin Department of Workforce Development or a similar agency in another state; or the U.S Department of Labor. This documentation is required prior to the Contractor beginning work on the project site.

Contract 8075 – Raymond P. Cattell, Inc.

The Contractor has reviewed the list and shall not use any apprenticeable trades on this project.

LIST APPRENTICABLE TRADES (check all that apply to your work to be performed on this contract)

- BRICKLAYER
- CARPENTER
- CEMENT MASON / CONCRETE FINISHER
- CEMENT MASON (HEAVY HIGHWAY)
- CONSTRUCTION CRAFT LABORER
- DATA COMMUNICATION INSTALLER
- ELECTRICIAN
- ENVIRONMENTAL SYSTEMS TECHNICIAN / HVAC SERVICE TECH/HVAC INSTALL / SERVICE
- GLAZIER
- HEAVY EQUIPMENT OPERATOR / OPERATING ENGINEER
- INSULATION WORKER (HEAT and FROST)
- IRON WORKER
- IRON WORKER (ASSEMBLER, METAL BLDGS)
- PAINTER and DECORATOR
- PLASTERER
- PLUMBER
- RESIDENTIAL ELECTRICIAN
- ROOFER and WATER PROOFER
- SHEET METAL WORKER
- SPRINKLER FITTER
- STEAMFITTER
- STEAMFITTER (REFRIGERATION)
- STEAMFITTER (SERVICE)
- TAPER and FINISHER
- TELECOMMUNICATIONS (VOICE, DATA and VIDEO) INSTALLER-TECHNICIAN
- TILE SETTER

SIDEWALK, CURB & GUTTER AND CONCRETE PAVEMENT PATCHES, CITYWIDE
INSTALLATION AND REPAIR – 2018
CONTRACT NO. 8075

Small Business Enterprise Compliance Report

This information may be submitted electronically through
Bid Express or submitted with bid in sealed envelope.

Cover Sheet

Prime Bidder Information

Company: Raymond P. Cattell Inc.
Address: 2401 Vandrom Road, Madison, wis 53718
Telephone Number: 608-222-3180 Fax Number: 608-222-2753
Contact Person/Title: Arthur Mackesey

Prime Bidder Certification

I, Arthur Mackesey, Secretary of
Name Title
Raymond P. Cattell Inc. certify that the information
Company

contained in this SBE Compliance Report is true and correct to the best of my knowledge and belief.

[Signature]
Witness Signature

[Signature]
Bidder's Signature

4/12/18
Date

**SIDEWALK, CURB & GUTTER AND CONCRETE PAVEMENT PATCHES, CITYWIDE
INSTALLATION AND REPAIR – 2018
CONTRACT NO. 8075**

Small Business Enterprise Compliance Report

Summary Sheet

SBE Subcontractors Who Are NOT Suppliers

Name(s) of SBEs Utilized	Type of Work	% of Total Bid Amount
JRIS Construction + Landscaping		5%
		%
		%
		%
		%
		%
		%
		%
		%
		%
		%
		%
		%
		%
		%
		%
		%
		%
		%
		%
Subtotal SBE who are NOT suppliers:		<u>5%</u> %

SBE Subcontractors Who Are Suppliers

Name(s) of SBEs Utilized	Type of Work	% of Total Bid Amount
		%
		%
		%
		%
		%
		%
		%
		%
		%
		%

Subtotal Contractors who are suppliers: _____ % x 0.6 = _____ % (discounted to 60%)

Total Percentage of SBE Utilization: 5% %.

**SIDEWALK, CURB & GUTTER AND CONCRETE PAVEMENT PATCHES, CITYWIDE
 INSTALLATION AND REPAIR - 2018
 CONTRACT NO. 8075
 DATE: 4/12/18**

Raymond P. Cattell, Inc.

Item	Quantity	Price	Extension
Section B: Proposal Page			
10801 - ROOT CUTTING - CURB & GUTTER - LF	50.00	\$5.00	\$250.00
10802 - ROOT CUTTING - SIDEWALK - LF	50.00	\$5.00	\$250.00
20101 - EXCAVATION CUT - CY	50.00	\$15.00	\$750.00
20218 - CRUSHED STONE - TON	75.00	\$15.00	\$1,125.00
20221 - TOPSOIL - SY	200.00	\$5.00	\$1,000.00
20302 - SAWCUT CONCRETE FULL DEPTH - LF	75.00	\$3.00	\$225.00
20303 - SAWCUT ASPHALT PAVEMENT - LF	75.00	\$3.00	\$225.00
20323 - REMOVE CONCRETE SIDEWALK & DRIVE - SF	150.00	\$3.00	\$450.00
20326 - REMOVING FENCE - LF	45.00	\$25.00	\$1,125.00
20401 - CLEARING - ID	20.00	\$15.00	\$300.00
20406 - GRUBBING - ID	20.00	\$15.00	\$300.00
20501 - ADJUST SEWER ACCESS STRUCTURE - EACH	1.00	\$500.00	\$500.00
20502 - ADJUST CATCH BASIN - EACH	1.00	\$500.00	\$500.00
20701 - TERRACE SEEDING - SY	200.00	\$5.00	\$1,000.00
21041 - INLET PROTECTION, TYPE D - COMPLETE (UNDISTRIBUTED) - EACH	5.00	\$50.00	\$250.00
21061 - EROSION MATTING, CLASS I, URBAN TYPE A (UNDISTRIBUTED) - SY	200.00	\$5.00	\$1,000.00
30101 - #4 EPOXY COATED PAVEMENT TIES - EACH	50.00	\$10.00	\$500.00
30103 - #6 EPOXY COATED PAVEMENT TIES - EACH	20.00	\$15.00	\$300.00
30201 - TYPE 'A' CONCRETE CURB & GUTTER - LF	25.00	\$20.00	\$500.00
30301 - 5 INCH CONCRETE SIDEWALK - SF	750.00	\$15.00	\$11,250.00
30302 - 7 INCH CONCRETE SIDEWALK AND DRIVE - SF	500.00	\$15.00	\$7,500.00
30330 - PROFILE SAWCUT - LF	30.00	\$30.00	\$900.00
30340 - CURB RAMP DETECTABLE WARNING FIELDS - SF	320.00	\$10.00	\$3,200.00
30342 - TREE GRATE 4' X 8' (INCLUDING FRAME) - EACH	2.00	\$1,500.00	\$3,000.00
30501 - REMOVE AND REPLACE 5 INCH CONCRETE SIDEWALK- SIDEWALK REPLACEMENT PROGRAM - SF	6500.00	\$22.00	\$143,000.00
30502 - REMOVE AND REPLACE 7 INCH CONCRETE SIDEWALK AND DRIVE-SIDEWALK REPLACEMENT PROGRAM - SF	2300.00	\$23.00	\$52,900.00
30503 - REMOVE AND REPLACE CONCRETE STEPS - SIDEWALK REPLACEMENT PROGRAM - SF	20.00	\$50.00	\$1,000.00
30504 - REMOVE EXISTING ASPHALT SIDEWALK & DRIVEWAY - SIDEWALK REPLACEMENT PROGRAM - SF	125.00	\$3.00	\$375.00
30505 - REMOVE AND REPLACE CONCRETE CURB & GUTTER - SIDEWALK REPLACEMENT PROGRAM - LF	1500.00	\$53.00	\$79,500.00
30506 - RESET BRICK PAVERS - SIDEWALK REPLACEMENT PROGRAM - SF	75.00	\$12.00	\$900.00
40202 - HMA PAVEMENT 4 LT 58-28 S - SY	150.00	\$75.00	\$11,250.00
40364 - ADJUST INLET CASTING, TYPE "H" - RESURFACING - EACH	2.00	\$400.00	\$800.00
40366 - REBUILD INLET - RESURFACING - EACH	1.00	\$1,500.00	\$1,500.00
40411 - CONCRETE PAVEMENT RECONSTRUCTION - SY	200.00	\$225.00	\$45,000.00
90001 - HIGH EARLY STRENGTH CONCRETE, REMOVE AND REPLACE 7 INCH CONCRETE SIDEWALK AND DRIVEWAY- SIDEWALK REPLACEMENT PROGRAM - SF	250.00	\$25.00	\$6,250.00

**SIDEWALK, CURB & GUTTER AND CONCRETE PAVEMENT PATCHES, CITYWIDE
 INSTALLATION AND REPAIR - 2018
 CONTRACT NO. 8075
 DATE: 4/12/18**

Raymond P. Cattell, Inc.

Item	Quantity	Price	Extension
90002 - HIGH EARLY STRENGTH CONCRETE, REMOVE AND REPLACE CONCRETE CURB & GUTTER - SIDEWALK REPLACEMENT PROGRAM - LF	75.00	\$60.00	\$4,500.00
90003 - BUS PAD - SF	800.00	\$25.00	\$20,000.00
90004 - C1 CONCRETE SIDEWALK, 7-INCH - SF	260.00	\$75.00	\$19,500.00
90005 - REMOVE AND REPLACE 7 INCH CONCRETE DRIVEWAY- FIRE STATION #3 - SF	2325.00	\$17.00	\$39,525.00
39 Items	Totals		\$462,400.00



Department of Public Works
Engineering Division
 Robert F. Phillips, P.E., City Engineer
 City-County Building, Room 115
 210 Martin Luther King, Jr. Boulevard
 Madison, Wisconsin 53703
 Phone: (608) 266-4751
 Fax: (608) 264-9275
engineering@cityofmadison.com
www.cityofmadison.com/engineering

Assistant City Engineer
 Gregory T. Friess, P.E.
 Kathleen M. Cryan

Principal Engineer 2
 Christopher J. Petykowski, P.E.
 John S. Fahrney, P.E.

Principal Engineer 1
 Christina M. Bachmann, P.E.
 Mark D. Moder, P.E.
 Janet Schmidt, P.E.

Facilities & Sustainability
 Jeanne E. Hoffman, Manager

Mapping Section Manager
 Eric T. Pederson, P.S.

Financial Manager
 Steven B. Danner-Rivers

BIENNIAL BID BOND

Raymond P. Cattell, Inc.

(a corporation of the State of Wisconsin)
 (individual), (partnership), (hereinafter referred to as the "Principal") and
The Ohio Casualty Insurance Company

a corporation of the State of New Hampshire (hereinafter referred to as the "Surety") and licensed to do business in the State of Wisconsin, are held and firmly bound unto the City of Madison, Wisconsin (hereinafter referred to as the "City"), in the sum equal to the individual proposal guaranty amounts of the total bid or bids of the Principal herein accepted by the City, for the payment of which the Principal and the Surety hereby jointly and severally bind ourselves, our heirs, executors, administrators, successors and assigns.

The condition of this obligation is that the Principal has submitted to the City certain bids for projects from the time period of February 1, 2018 through February 1, 2020.

If the Principal is awarded the contract(s) by the City and, within the time and manner required by law after the prescribed forms are presented for its signature, the Principal enters into (a) written contract(s) in accordance with the bid(s), and files with the City its bond(s) guaranteeing faithful performance and payment for all labor and materials, as required by law, or if the City rejects all bids for the work described, then this obligation shall be null and void; otherwise, it shall remain in full force and effect.

In the event the Principal shall fail to execute and deliver the contract(s) or the performance and payment bond(s), all within the time specified or any extension thereof, the Principal and Surety agree jointly and severally to pay to the City within ten (10) calendar days of written demand a total equal to the sum of the individual proposal guaranty amounts of the total bid(s) as liquidated damages.

The Surety, for value received, hereby agrees that the obligations of it and its bond shall be in no way impaired or affected by any extension of time within which the City may accept a bid, and the Surety does hereby waive notice of any such extension.

This bond may be terminated by the Surety upon giving thirty (30) days written notice to the City of its intent to terminate this bond and to be released and discharged therefrom, but such termination shall not operate to relieve or discharge the Surety from any liability already accrued or which shall accrue before the expiration of such thirty (30) day period.

IN WITNESS WHEREOF, the Principal and the Surety have hereunto set their hands and seals, and such of them as are corporations have caused their corporate seals to be hereto affixed and these presents to be signed by their proper officers, on the day and year set forth below.

PRINCIPAL

Raymond P. Cattell February 1, 2018
COMPANY NAME AFFIX SEAL DATE

By: *Raymond P. Cattell* Secy
SIGNATURE AND TITLE

SURETY

The Ohio Casualty Insurance Company February 1, 2018
COMPANY NAME AFFIX SEAL DATE

By: *Michael J. Nolen* Attorney-In-Fact
SIGNATURE AND TITLE

This certifies that I have been duly licensed as an agent for the Surety in Wisconsin under National Provider No. 14840439 for the year 2018 and appointed as attorney in fact with authority to execute this bid bond, which power of attorney has not been revoked.

February 1, 2018
DATE

Michael J. Nolen
AGENT SIGNATURE

828 John Nolen Drive
ADDRESS

Madison, WI 53713
CITY, STATE AND ZIP CODE

608-288-2893
TELEPHONE NUMBER

Note to Surety and Principal: Any bid submitted which this bond guarantees may be rejected if the Power of Attorney form showing that the Agent of Surety is currently authorized to execute bonds on behalf of Surety is not attached to this bond.

CERTIFICATE OF BIENNIAL BID BOND

TIME PERIOD- VALID (FROM/TO) February 1, 2018 - February 1, 2020
NAME OF SURETY The Ohio Casualty Insurance Company
NAME OF CONTRACTOR Raymond P. Cattell, Inc.
CERTIFICATE HOLDER City of Madison, Wisconsin

This is to certify that a biennial bid bond issued by the above-named Surety is currently on file with the City of Madison.

This certificate is issued as a matter of information and conveys no rights upon the certificate holder and does not amend, extend or alter the coverage of the biennial bid bond.

Cancellation: Should the above policy be cancelled before the expiration date, the issuing Surety will give thirty (30) days written notice to the certificate holder indicated above.

SIGNATURE OF AUTHORIZED CONTRACTOR REPRESENTATIVE

February 1, 2018
DATE

THIS POWER OF ATTORNEY IS NOT VALID UNLESS IT IS PRINTED ON RED BACKGROUND.

This Power of Attorney limits the acts of those named herein, and they have no authority to bind the Company except in the manner and to the extent herein stated.

Certificate No. 7989373

Liberty Mutual Insurance Company
The Ohio Casualty Insurance Company West American Insurance Company

POWER OF ATTORNEY

KNOWN ALL PERSONS BY THESE PRESENTS: That The Ohio Casualty Insurance Company is a corporation duly organized under the laws of the State of New Hampshire, that Liberty Mutual Insurance Company is a corporation duly organized under the laws of the State of Massachusetts, and West American Insurance Company is a corporation duly organized under the laws of the State of Indiana (herein collectively called the "Companies"), pursuant to and by authority herein set forth, does hereby name, constitute and appoint, Michael J. Moore; Travis Schreiber; Richard F. Kekula; Kim E. Schwenn; Trisha Stark; Michael R. Zahn; Julie Zimmerman

all of the city of Madison, state of WI each individually if there be more than one named, its true and lawful attorney-in-fact to make, execute, seal, acknowledge and deliver, for and on its behalf as surety and as its act and deed, any and all undertakings, bonds, recognizances and other surety obligations, in pursuance of these presents and shall be as binding upon the Companies as if they have been duly signed by the president and attested by the secretary of the Companies in their own proper persons.

IN WITNESS WHEREOF, this Power of Attorney has been subscribed by an authorized officer or official of the Companies and the corporate seals of the Companies have been affixed thereto this 24th day of January, 2018



The Ohio Casualty Insurance Company
Liberty Mutual Insurance Company
West American Insurance Company

By: David M. Carey
David M. Carey, Assistant Secretary

STATE OF PENNSYLVANIA ss
COUNTY OF MONTGOMERY

On this 24th day of January, 2018, before me personally appeared David M. Carey, who acknowledged himself to be the Assistant Secretary of Liberty Mutual Insurance Company, The Ohio Casualty Company, and West American Insurance Company, and that he, as such, being authorized so to do, execute the foregoing instrument for the purposes therein contained by signing on behalf of the corporations by himself as a duly authorized officer.

IN WITNESS WHEREOF, I have hereunto subscribed my name and affixed my notarial seal at King of Prussia, Pennsylvania, on the day and year first above written.



COMMONWEALTH OF PENNSYLVANIA
Notarial Seal
Teresa Pastella, Notary Public
Upper Merion Twp., Montgomery County
My Commission Expires March 28, 2021
Member, Pennsylvania Association of Notaries

By: Teresa Pastella
Teresa Pastella, Notary Public

This Power of Attorney is made and executed pursuant to and by authority of the following By-laws and Authorizations of The Ohio Casualty Insurance Company, Liberty Mutual Insurance Company, and West American Insurance Company which resolutions are now in full force and effect reading as follows:

ARTICLE IV – OFFICERS – Section 12. Power of Attorney. Any officer or other official of the Corporation authorized for that purpose in writing by the Chairman or the President, and subject to such limitation as the Chairman or the President may prescribe, shall appoint such attorneys-in-fact, as may be necessary to act in behalf of the Corporation to make, execute, seal, acknowledge and deliver as surety any and all undertakings, bonds, recognizances and other surety obligations. Such attorneys-in-fact, subject to the limitations set forth in their respective powers of attorney, shall have full power to bind the Corporation by their signature and execution of any such instruments and to attach thereto the seal of the Corporation. When so executed, such instruments shall be as binding as if signed by the President and attested to by the Secretary. Any power or authority granted to any representative or attorney-in-fact under the provisions of this article may be revoked at any time by the Board, the Chairman, the President or by the officer or officers granting such power or authority.

ARTICLE XIII – Execution of Contracts – SECTION 5. Surety Bonds and Undertakings. Any officer of the Company authorized for that purpose in writing by the chairman or the president, and subject to such limitations as the chairman or the president may prescribe, shall appoint such attorneys-in-fact, as may be necessary to act in behalf of the Company to make, execute, seal, acknowledge and deliver as surety any and all undertakings, bonds, recognizances and other surety obligations. Such attorneys-in-fact subject to the limitations set forth in their respective powers of attorney, shall have full power to bind the Company by their signature and execution of any such instruments and to attach thereto the seal of the Company. When so executed such instruments shall be as binding as if signed by the president and attested by the secretary.

Certificate of Designation – The President of the Company, acting pursuant to the Bylaws of the Company, authorizes David M. Carey, Assistant Secretary to appoint such attorneys-in-fact as may be necessary to act on behalf of the Company to make, execute, seal, acknowledge and deliver as surety any and all undertakings, bonds, recognizances and other surety obligations.

Authorization – By unanimous consent of the Company's Board of Directors, the Company consents that facsimile or mechanically reproduced signature of any assistant secretary of the Company, wherever appearing upon a certified copy of any power of attorney issued by the Company in connection with surety bonds, shall be valid and binding upon the Company with the same force and effect as though manually affixed.

I, Renee C. Llewellyn, the undersigned, Assistant Secretary, The Ohio Casualty Insurance Company, Liberty Mutual Insurance Company, and West American Insurance Company do hereby certify that the original power of attorney of which the foregoing is a full, true and correct copy of the Power of Attorney executed by said Companies, is in full force and effect and has not been revoked.

IN TESTIMONY WHEREOF, I have hereunto set my hand and affixed the seals of said Companies this 15th day of February, 2018

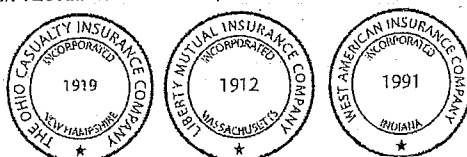

By: Renee C. Llewellyn
Renee C. Llewellyn, Assistant Secretary

currency rate, interest rate or residual value guarantees.

To confirm the validity of this Power of Attorney call 1-610-832-8240 between 9:00 am and 4:30 pm EST on any business day.

SECTION H: AGREEMENT

THIS AGREEMENT made this 2d day of MAY in the year Two Thousand and Eighteen between RAYMOND P. CATTELL, INC. hereinafter called the Contractor, and the City of Madison, Wisconsin, hereinafter called the City.

WHEREAS, the Common Council of the said City of Madison under the provisions of a resolution adopted MAY 1, 2018, and by virtue of authority vested in the said Council, has awarded to the Contractor the work of performing certain construction.

NOW, THEREFORE, the Contractor and the City, for the consideration hereinafter named, agree as follows:

1. **Scope of Work.** The Contractor shall, perform the construction, execution and completion of the following listed complete work or improvement in full compliance with the Plans, Specifications, Standard Specifications, Supplemental Specifications, Special Provisions and contract; perform all items of work covered or stipulated in the proposal; perform all altered or extra work; and shall furnish, unless otherwise provided in the contract, all materials, implements, machinery, equipment, tools, supplies, transportation, and labor necessary to the prosecution and completion of the work or improvements:

SIDEWALK, CURB & GUTTER AND CONCRETE PAVEMENT PATCHES, CITYWIDE INSTALLATION AND REPAIR – 2018 CONTRACT NO. 8075

2. **Completion Date/Contract Time.** Construction work must begin within seven (7) calendar days after the date appearing on mailed written notice to do so shall have been sent to the Contractor and shall be carried on at a rate so as to secure full completion SEE SPECIAL PROVISIONS, the rate of progress and the time of completion being essential conditions of this Agreement.
3. **Contract Price.** The City shall pay to the Contractor at the times, in the manner and on the conditions set forth in said specifications, the sum of FOUR HUNDRED SIXTY-TWO THOUSAND FOUR HUNDRED AND NO/100 (\$462,400.00) Dollars being the amount bid by such Contractor and which was awarded to him/her as provided by law.
4. **Affirmative Action.** In the performance of the services under this Agreement the Contractor agrees not to discriminate against any employee or applicant because of race, religion, marital status, age, color, sex, disability, national origin or ancestry, income level or source of income, arrest record or conviction record, less than honorable discharge, physical appearance, sexual orientation, gender identity, political beliefs, or student status. The Contractor further agrees not to discriminate against any subcontractor or person who offers to subcontract on this contract because of race, religion, color, age, disability, sex, sexual orientation, gender identity or national origin.

The Contractor agrees that within thirty (30) days after the effective date of this agreement, the Contractor will provide to the City Affirmative Action Division certain workforce utilization statistics, using a form to be furnished by the City.

If the contract is still in effect, or if the City enters into a new agreement with the Contractor, within one year after the date on which the form was required to be provided, the Contractor will provide updated workforce information using a second form, also to be furnished by the City. The second form will be submitted to the City Affirmative Action Division no later than one year after the date on which the first form was required to be provided.

The Contractor further agrees that, for at least twelve (12) months after the effective date of this contract, it will notify the City Affirmative Action Division of each of its job openings at facilities in Dane County for which applicants not already employees of the Contractor are to be considered.

The notice will include a job description, classification, qualifications and application procedures and deadlines. The Contractor agrees to interview and consider candidates referred by the Affirmative Action Division if the candidate meets the minimum qualification standards established by the Contractor, and if the referral is timely. A referral is timely if it is received by the Contractor on or before the date started in the notice.

Articles of Agreement

Article I

The Contractor shall take affirmative action in accordance with the provisions of this contract to insure that applicants are employed, and that employees are treated during employment without regard to race, religion, color, age, marital status, disability, sex, sexual orientation, gender identity or national origin and that the employer shall provide harassment free work environment for the realization of the potential of each employee. Such action shall include, but not be limited to, the following: employment, upgrading, demotion or transfer, recruitment or recruitment advertising, layoff or termination, rates of pay or other forms of compensation and selection for training including apprenticeship insofar as it is within the control of the Contractor. The Contractor agrees to post in conspicuous places available to employees and applicants notices to be provided by the City setting out the provisions of the nondiscrimination clauses in this contract.

Article II

The Contractor shall in all solicitations or advertisements for employees placed by or on behalf of the Contractors state that all qualified or qualifiable applicants will be employed without regard to race, religion, color, age, marital status, disability, sex, sexual orientation, gender identity or national origin.

Article III

The Contractor shall send to each labor union or representative of workers with which it has a collective bargaining agreement or other contract or understanding a notice to be provided by the City advising the labor union or worker's representative of the Contractor's equal employment opportunity and affirmative action commitments. Such notices shall be posted in conspicuous places available to employees and applicants for employment.

Article V

The Contractor agrees that it will comply with all provisions of the Affirmative Action Ordinance of the City of Madison, including the contract compliance requirements. The Contractor agrees to submit the model affirmative action plan for public works contractors in a form approved by the Affirmative Action Division Manager.

Article VI

The Contractor will maintain records as required by Section 39.02(9)(f) of the Madison General Ordinances and will provide the City Affirmative Action Division with access to such records and to persons who have relevant and necessary information, as provided in Section 39.02(9)(f). The City agrees to keep all such records confidential, except to the extent that public inspection is required by law.

Article VII

In the event of the Contractor's or subcontractor's failure to comply with the Equal Employment Opportunity and Affirmative Action Provisions of this contract or Section 39.03 and 39.02 of the Madison General Ordinances, it is agreed that the City at its option may do any or all of the following:

1. Cancel, terminate or suspend this Contract in whole or in part.
2. Declare the Contractor ineligible for further City contracts until the Affirmative Action requirements are met.
3. Recover on behalf of the City from the prime Contractor 0.5 percent of the contract award price for each week that such party fails or refuses to comply, in the nature of liquidated damages, but not to exceed a total of five percent (5%) of the contract price, or five thousand dollars (\$5,000), whichever is less. Under public works contracts, if a subcontractor is in noncompliance, the City may recover liquidated damages from the prime Contractor in the manner described above. The preceding sentence shall not be construed to prohibit a prime Contractor from recovering the amount of such damage from the non-complying subcontractor.

Article VIII

The Contractor shall include the above provisions of this contract in every subcontract so that such provisions will be binding upon each subcontractor. The Contractor shall take such action with respect to any subcontractor as necessary to enforce such provisions, including sanctions provided for noncompliance.

Article IX

The Contractor shall allow the maximum feasible opportunity to small business enterprises to compete for any subcontracts entered into pursuant to this contract. (In federally funded contracts the terms "DBE, MBE and WBE" shall be substituted for the term "small business" in this Article.)

5. Substance Abuse Prevention Program Required. Prior to commencing work on the Contract, the Contractor, and any Subcontractor, shall have in place a written program for the prevention of substance abuse among its employees as required under Wis. Stat. Sec. 103.503.
6. **Contractor Hiring Practices.**

Ban the Box - Arrest and Criminal Background Checks. (Sec. 39.08, MGO)

This provision applies to all prime contractors on contracts entered into on or after January 1, 2016, and all subcontractors who are required to meet prequalification requirements under MGO 33.07(7)(l), MGO as of the first time they seek or renew pre-qualification status on or after January 1, 2016. The City will monitor compliance of subcontractors through the pre-qualification process.

- a. **Definitions.** For purposes of this section, "Arrest and Conviction Record" includes, but is not limited to, information indicating that a person has been questioned, apprehended, taken into custody or detention, held for investigation, arrested, charged with, indicted or tried for any felony, misdemeanor or other offense pursuant to any law enforcement or military authority.

"Conviction record" includes, but is not limited to, information indicating that a person has been convicted of a felony, misdemeanor or other offense, placed on probation, fined, imprisoned or paroled pursuant to any law enforcement or military authority.

"Background Check" means the process of checking an applicant's arrest and conviction record, through any means.

- b. **Requirements.** For the duration of this Contract, the Contractor shall:

1. Remove from all job application forms any questions, check boxes, or other inquiries regarding an applicant's arrest and conviction record, as defined herein.
2. Refrain from asking an applicant in any manner about their arrest or conviction record until after conditional offer of employment is made to the applicant in question.
3. Refrain from conducting a formal or informal background check or making any other inquiry using any privately or publicly available means of obtaining the arrest or conviction record of an applicant until after a conditional offer of employment is made to the applicant in question.
4. Make information about this ordinance available to applicants and existing employees, and post notices in prominent locations at the workplace with information about the ordinance and complaint procedure using language provided by the City.
5. Comply with all other provisions of Sec. 39.08, MGO.

c. Exemptions: This section shall not apply when:

1. Hiring for a position where certain convictions or violations are a bar to employment in that position under applicable law, or
2. Hiring a position for which information about criminal or arrest record, or a background check is required by law to be performed at a time or in a manner that would otherwise be prohibited by this ordinance, including a licensed trade or profession where the licensing authority explicitly authorizes or requires the inquiry in question.

To be exempt, Contractor has the burden of demonstrating that there is an applicable law or regulation that requires the hiring practice in question, if so, the contractor is exempt from all of the requirements of this ordinance for the position(s) in question.

**SIDEWALK, CURB & GUTTER AND CONCRETE PAVEMENT PATCHES, CITYWIDE
INSTALLATION AND REPAIR – 2018
CONTRACT NO. 8075**

IN WITNESS WHEREOF, the Contractor has hereunto set his/her hand and seal and the City has caused these presents to be sealed with its corporate seal and to be subscribed by its Mayor and City Clerk the day and year first above written.

Countersigned:

[Signature] 5/2/18
 Witness Date
[Signature] 5/2/18
 Witness Date

RAYMOND P. CATTELL, INC.

RAYMOND P. CATTELL, INC.
 Company Name
[Signature] 5-2-2018
 President Date
[Signature] 5-2-2018
 Secretary Date

CITY OF MADISON, WISCONSIN

Provisions have been made to pay the liability that will accrue under this contract.

[Signature]
 Finance Director
 Signed this 18th day of May
[Signature]
 Witness
[Signature]
 Witness

Approved as to form:

[Signature]
 City Attorney
[Signature] 20 18
 Mayor Date
[Signature] 16 May 2018
 City Clerk Date

SECTION I: PAYMENT AND PERFORMANCE BOND

KNOW ALL MEN BY THESE PRESENTS, that we RAYMOND P. CATTELL, INC. as principal, and The Ohio Casualty Insurance Company Company of New Hampshire as surety, are held and firmly bound unto the City of Madison, Wisconsin, in the sum of **FOUR HUNDRED SIXTY-TWO THOUSAND FOUR HUNDRED AND NO/100 (\$462,400.00)** Dollars, lawful money of the United States, for the payment of which sum to the City of Madison, we hereby bind ourselves and our respective executors and administrators firmly by these presents.

The condition of this Bond is such that if the above bounden shall on his/her part fully and faithfully perform all of the terms of the Contract entered into between him/herself and the City of Madison for the construction of:

**SIDEWALK, CURB & GUTTER AND CONCRETE PAVEMENT PATCHES, CITYWIDE INSTALLATION AND REPAIR – 2018
CONTRACT NO. 8075**

in Madison, Wisconsin, and shall pay all claims for labor performed and material furnished in the prosecution of said work, and save the City harmless from all claims for damages because of negligence in the prosecution of said work, and shall save harmless the said City from all claims for compensation (under Chapter 102, Wisconsin Statutes) of employees and employees of subcontractor, then this Bond is to be void, otherwise of full force, virtue and effect.

Signed and sealed this 2nd day of May, 2018

Countersigned:

RAYMOND P. CATTELL, INC.

Company Name (Principal)

Witness

President

Seal

Secretary

Approved as to form:

The Ohio Casualty Insurance Company

Surety

Seal

Salary Employee

Commission

By

Attorney-in-Fact

Michael R. Zahn

City Attorney

This certifies that I have been duly licensed as an agent for the above company in Wisconsin under National Producer Number 14840439 for the year 2018, and appointed as attorney-in-fact with authority to execute this payment and performance bond which power of attorney has not been revoked.

May 2, 2018

Date

Agent Signature

Michael R. Zahn

THIS POWER OF ATTORNEY IS NOT VALID UNLESS IT IS PRINTED ON RED BACKGROUND.

This Power of Attorney limits the acts of those named herein, and they have no authority to bind the Company except in the manner and to the extent herein stated.

Certificate No. 7989415

Liberty Mutual Insurance Company
The Ohio Casualty Insurance Company West American Insurance Company

POWER OF ATTORNEY

KNOWN ALL PERSONS BY THESE PRESENTS: That The Ohio Casualty Insurance Company is a corporation duly organized under the laws of the State of New Hampshire, that Liberty Mutual Insurance Company is a corporation duly organized under the laws of the State of Massachusetts, and West American Insurance Company is a corporation duly organized under the laws of the State of Indiana (herein collectively called the "Companies"), pursuant to and by authority herein set forth, does hereby name, constitute and appoint, Michael J. Moore; Travis Schreiber; Richard F. Kekula; Kim E. Schwenn; Trisha Stark; Michael R. Zahn; Julie Zimmerman

all of the city of Madison, state of WI each individually if there be more than one named, its true and lawful attorney-in-fact to make, execute, seal, acknowledge and deliver, for and on its behalf as surety and as its act and deed, any and all undertakings, bonds, recognizances and other surety obligations, in pursuance of these presents and shall be as binding upon the Companies as if they have been duly signed by the president and attested by the secretary of the Companies in their own proper persons.

IN WITNESS WHEREOF, this Power of Attorney has been subscribed by an authorized officer or official of the Companies and the corporate seals of the Companies have been affixed thereto this 24th day of January, 2018.



The Ohio Casualty Insurance Company
Liberty Mutual Insurance Company
West American Insurance Company

By: David M. Carey
David M. Carey, Assistant Secretary

STATE OF PENNSYLVANIA ss
COUNTY OF MONTGOMERY

On this 24th day of January, 2018, before me personally appeared David M. Carey, who acknowledged himself to be the Assistant Secretary of Liberty Mutual Insurance Company, The Ohio Casualty Company, and West American Insurance Company, and that he, as such, being authorized so to do, execute the foregoing instrument for the purposes therein contained by signing on behalf of the corporations by himself as a duly authorized officer.

IN WITNESS WHEREOF, I have hereunto subscribed my name and affixed my notarial seal at King of Prussia, Pennsylvania, on the day and year first above written.



COMMONWEALTH OF PENNSYLVANIA
Notarial Seal
Teresa Pastella, Notary Public
Upper Merion Twp., Montgomery County
My Commission Expires March 28, 2021
Member, Pennsylvania Association of Notaries

By: Teresa Pastella
Teresa Pastella, Notary Public

This Power of Attorney is made and executed pursuant to and by authority of the following By-laws and Authorizations of The Ohio Casualty Insurance Company, Liberty Mutual Insurance Company, and West American Insurance Company which resolutions are now in full force and effect reading as follows:

ARTICLE IV – OFFICERS – Section 12. Power of Attorney. Any officer or other official of the Corporation authorized for that purpose in writing by the Chairman or the President, and subject to such limitation as the Chairman or the President may prescribe, shall appoint such attorneys-in-fact, as may be necessary to act in behalf of the Corporation to make, execute, seal, acknowledge and deliver as surety any and all undertakings, bonds, recognizances and other surety obligations. Such attorneys-in-fact, subject to the limitations set forth in their respective powers of attorney, shall have full power to bind the Corporation by their signature and execution of any such instruments and to attach thereto the seal of the Corporation. When so executed, such instruments shall be as binding as if signed by the President and attested to by the Secretary. Any power or authority granted to any representative or attorney-in-fact under the provisions of this article may be revoked at any time by the Board, the Chairman, the President or by the officer or officers granting such power or authority.

ARTICLE XIII – Execution of Contracts – SECTION 5. Surety Bonds and Undertakings. Any officer of the Company authorized for that purpose in writing by the chairman or the president, and subject to such limitations as the chairman or the president may prescribe, shall appoint such attorneys-in-fact, as may be necessary to act in behalf of the Company to make, execute, seal, acknowledge and deliver as surety any and all undertakings, bonds, recognizances and other surety obligations. Such attorneys-in-fact subject to the limitations set forth in their respective powers of attorney, shall have full power to bind the Company by their signature and execution of any such instruments and to attach thereto the seal of the Company. When so executed such instruments shall be as binding as if signed by the president and attested by the secretary.

Certificate of Designation – The President of the Company, acting pursuant to the Bylaws of the Company, authorizes David M. Carey, Assistant Secretary to appoint such attorneys-in-fact as may be necessary to act on behalf of the Company to make, execute, seal, acknowledge and deliver as surety any and all undertakings, bonds, recognizances and other surety obligations.

Authorization – By unanimous consent of the Company's Board of Directors, the Company consents that facsimile or mechanically reproduced signature of any assistant secretary of the Company, wherever appearing upon a certified copy of any power of attorney issued by the Company in connection with surety bonds, shall be valid and binding upon the Company with the same force and effect as though manually affixed.

I, Renee C. Llewellyn, the undersigned, Assistant Secretary, The Ohio Casualty Insurance Company, Liberty Mutual Insurance Company, and West American Insurance Company do hereby certify that the original power of attorney of which the foregoing is a full, true and correct copy of the Power of Attorney executed by said Companies, is in full force and effect and has not been revoked.

IN TESTIMONY WHEREOF, I have hereunto set my hand and affixed the seals of said Companies this 2nd day of May, 2018.



By: Renee C. Llewellyn
Renee C. Llewellyn, Assistant Secretary

Not valid for mortgage, note, loan, letter of credit, currency rate, interest rate or residual value guarantees.

To confirm the validity of this Power of Attorney call 1-610-832-8240 between 9:00 am and 4:30 pm EST on any business day.